



WISCONSIN WASTEWATER
OPERATORS' ASSOCIATION

WWOA

Virtual Operator Training Series

- 💧 April 30th Activated Sludge 9am – Noon
- 💧 May 6th Anaerobic Digestion 9am – Noon
- 💧 May 14th Collection System Operations 9am – Noon
- 💧 May 21st WI DNR Updates 11am-1pm
- 💧 May 26th Water Quality Trading 9am – Noon
- 💧 June 4th Submersible Pump O&M 9am – Noon
- 💧 June 10th Biosolids Handling Case Studies 9am – Noon
- 💧 June 17th Process Control 9am - Noon

Webinar Meeting Details

Welcome from the WWOA, thank you for continuing your education with us during these historically unique times.

- Find the chat function, you will need that to answer simple questions designed to confirm that you are still participating.
 - This is necessary to get credits.
- Breaks will be 5 minutes, we will start promptly following each break.
- Questions can be asked through the question feature, we will check in on them periodically.
- A short survey will be included at the conclusion.
 - We need feedback to improve this approach to continued educational opportunities.

The content of this presentation is intended for the sole purpose of educating WWOA members and is not to be downloaded, copied, used, shared, or otherwise transmitted without the prior consent of WWOA and the authors.





Wisconsin Wastewater
Operators' Association

WWOA would like to thank our generous sponsors and partners for their support of our mission to provide training and education opportunities for our members and others working in the water and wastewater profession.

2020 WWOA Virtual Operator Training Series

Accessible ~ Affordable ~ Informative

Anaerobic Digestion Virtual Operator Training ~ May 6, 2020

PRESENTING SPONSOR:



CONTRIBUTING SPONSORS:



Introductions



Lindsey Busch, PE



Brian Graham, PE



Becky Luna, PE



Rashi Gupta, PE



// Anaerobic Digestion Virtual Training Agenda

- Part 1: Back to the Basics
 - Process
 - Part 503 Requirements
 - Process Fundamentals/Design Parameters
 - Configurations
- Part 2: Operations
 - Sludge Feeding and Loading
 - Mixing
 - Heating
 - Digester Gas Systems
 - Operating Parameters
 - Troubleshooting
- Part 3: Emerging Technology/Innovations
 - Pre-Digestion Processes
 - Advanced Digestion
 - Post-Digestion Processes
 - Biogas

Polling Question

- What has been your favorite part of spending more time at home?
 - a) Cooking
 - b) Mowing the lawn
 - c) Spending time with family
 - d) None of the above. When will it ever end?

Back to the Basics

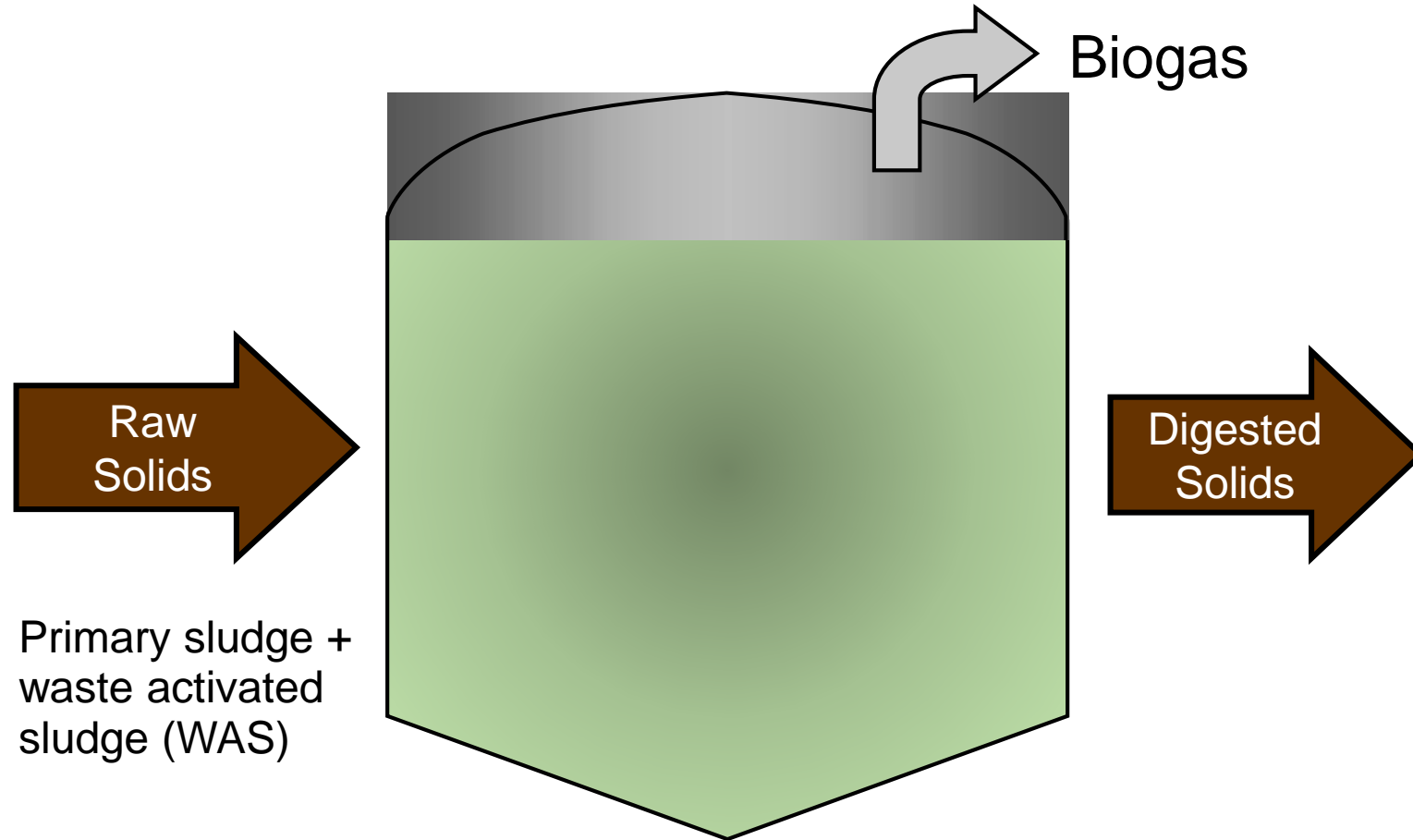

Why digest?

- Reduce solids → Lower hauling/solids handling costs
- Reduce pathogens → Safer land application/reuse
- Produce digester gas (methane) → Harness to produce energy
- Divert organics from landfills → Produce renewable energy, reduce GHGs





Anaerobic Digestion Process

Anaerobic digestion is perceived as a simple process

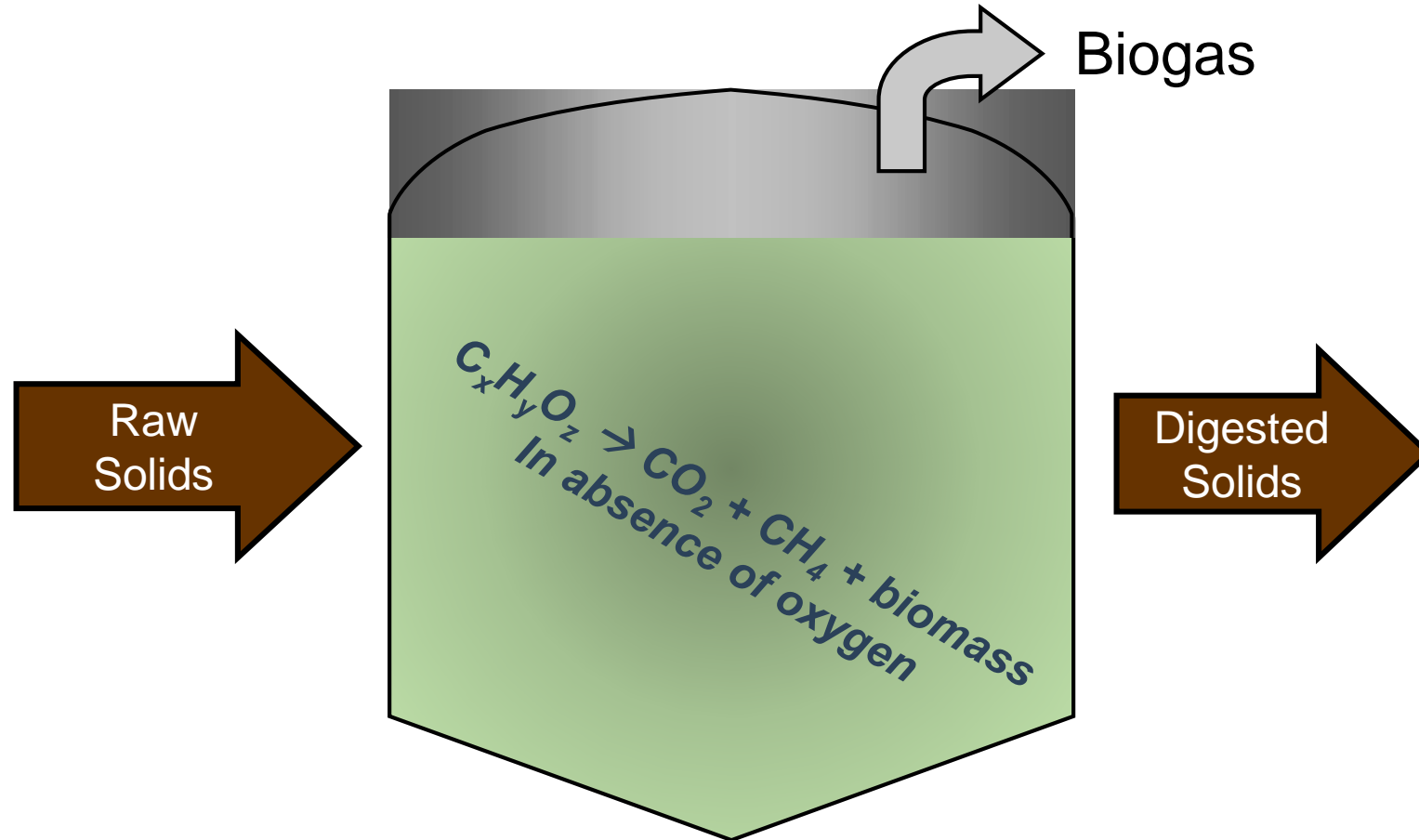

In reality, it is a complex and changing system

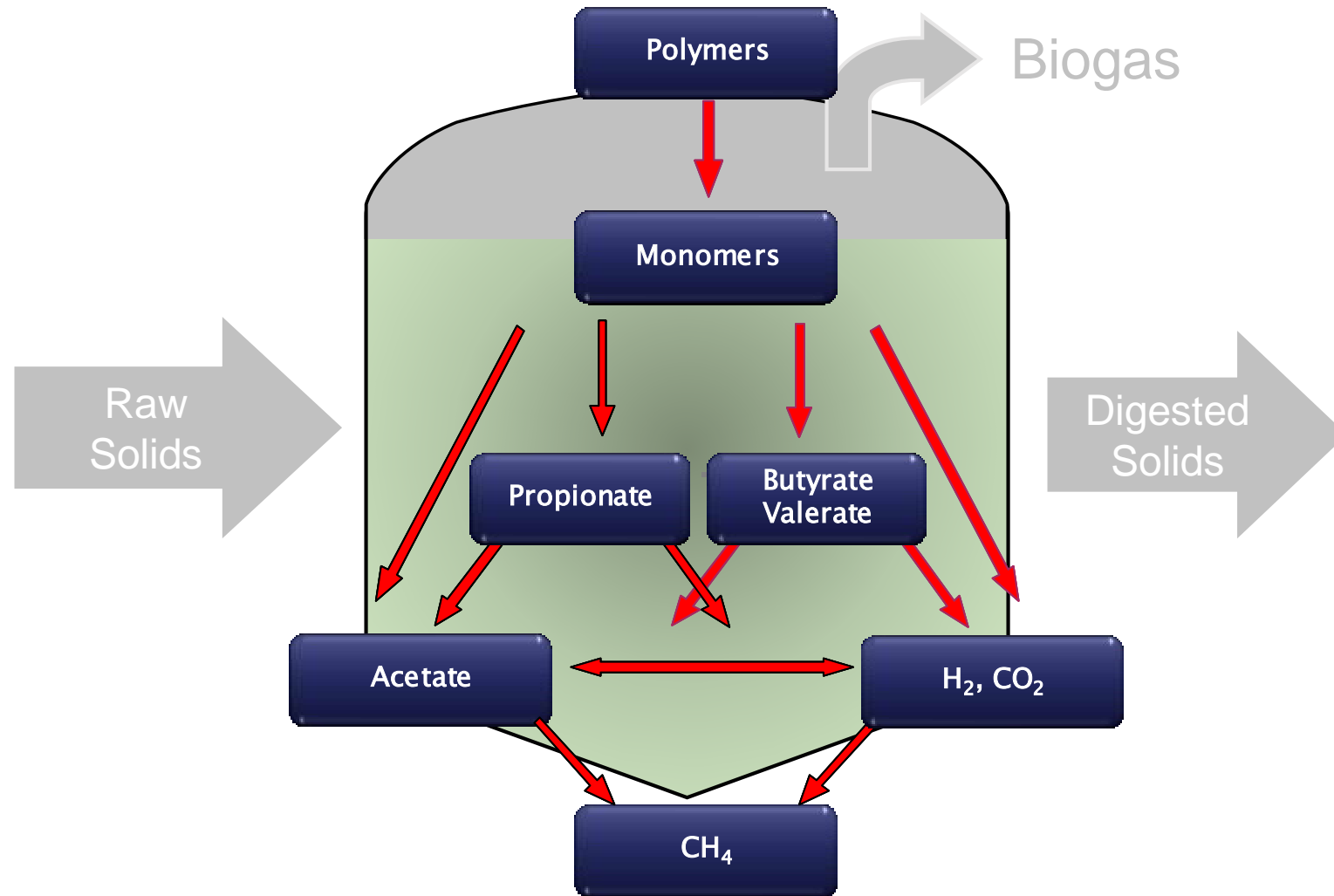

Polling Question

- What is the first stage of anaerobic digestion?
 - a) Methanogenesis
 - b) Biogas production
 - c) A long word I can't pronounce
 - d) Hydrolysis

Anaerobic digestion involves three (or four) sequential steps

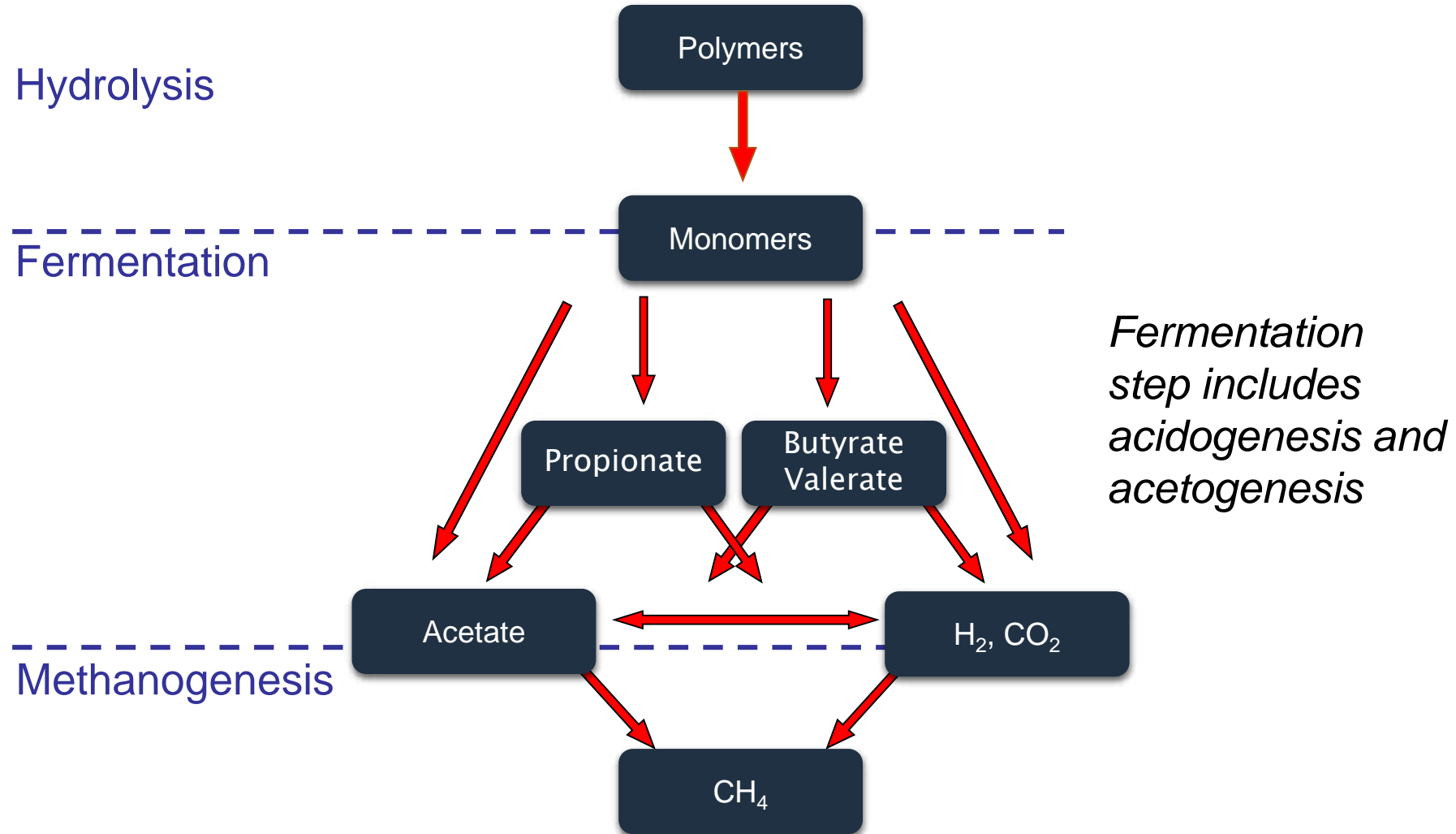

Biological involvement in steps

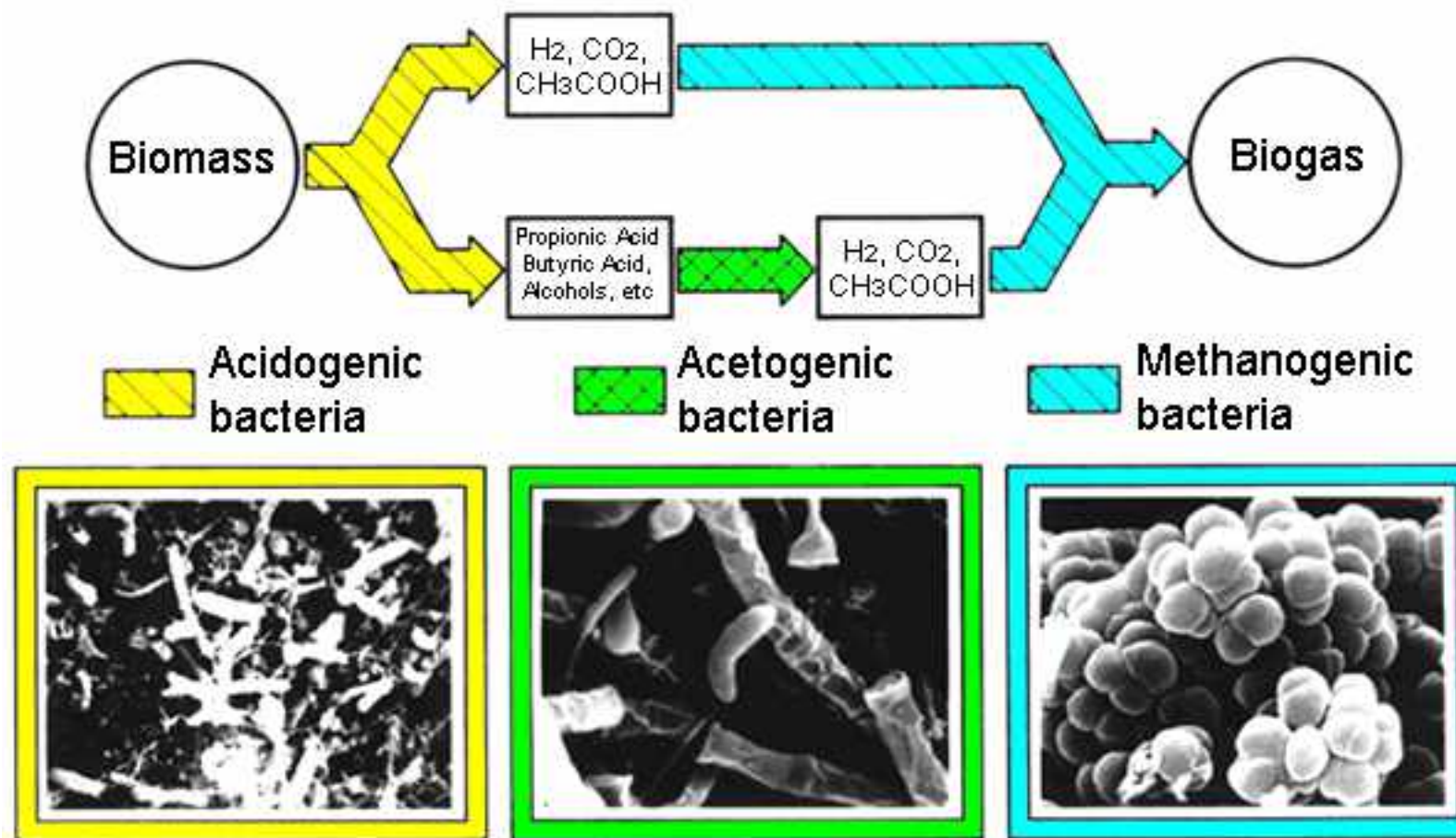

© 2009, WtERT GmbH

Hydrolysis

- Break large particles into smaller ones
 - Process step works best with small material
 - Enzymes are required for process to proceed
- Complex organic matter to simple monomers
 - e.g.: $C_xH_yO_z + 2H_2O \rightarrow C_6H_{12}O_6$ (glucose) + H_2
- Impacted by retention time
- Some organics difficult to hydrolyze (lignins, etc.)

Fermentation

- Acidogenesis
- Conversion of monomers to volatile acids, ketones, alcohols, hydrogen and carbon dioxide
 - Products:
 - Propionic acid ($\text{CH}_3\text{CH}_2\text{COOH}$)
 - Butyric acid ($\text{CH}_3\text{CH}_2\text{CH}_2\text{COOH}$)
 - Acetic acid (CH_3COOH)
 - Formic acid (HCOOH)
 - Lactic acid ($\text{C}_3\text{H}_6\text{O}_3$)
 - Ethanol ($\text{C}_2\text{H}_5\text{OH}$)
 - Methanol (CH_3OH)

Fermentation

- Break down longer chain VFAs, alcohols, etc. into H_2 , CO_2 , and acetic acid that can be used by methanogens in next step
- Reaction impacted by H_2 partial pressure
- Rate fastest when H_2 low (methanogens consuming)

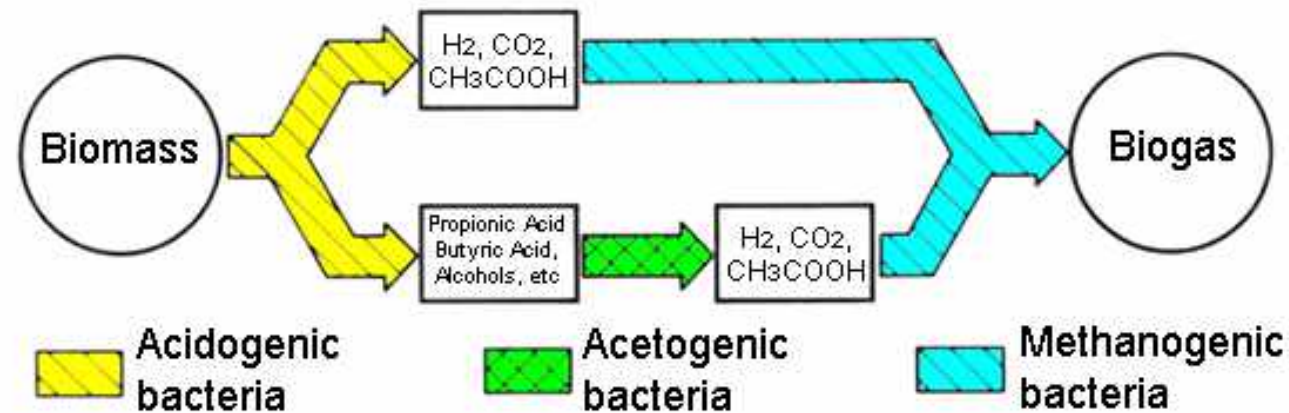

Methanogenesis

- Acetic acid, hydrogen, and carbon dioxide converted to methane, carbon dioxide, and water
- Lithotrophic methanogens (use H_2 and $\text{CO}_2 \rightarrow \text{CH}_4$)
 - Responsible for 30% of methane production
 - Thermodynamically favorable
- Acetoclastic methanogens (use acetate $\rightarrow \text{CH}_4$)
 - Responsible for 70% of methane production
 - Thermodynamically unfavorable
- Slow growing biology; slow process
- Susceptible to loading rate, pH, and ammonia concentrations

Methanogens

The Archaea

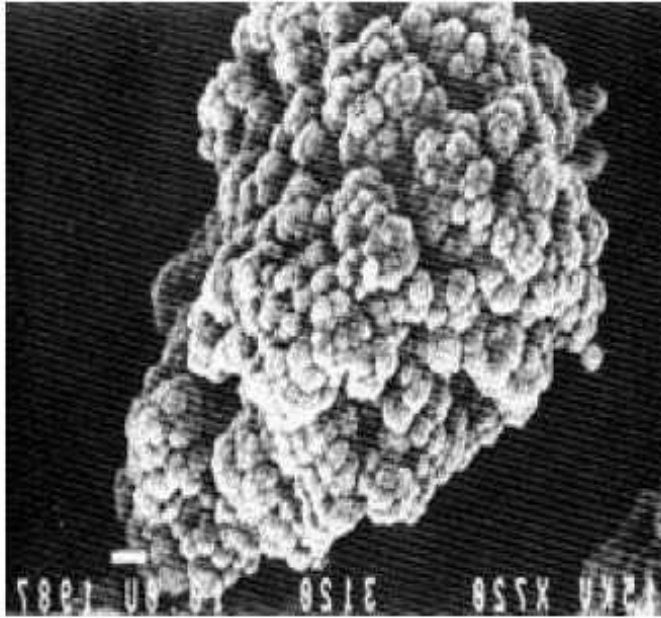

Scanning electron micrograph of a cocci-shaped archaea from the genus *Methanosarcina*. Members of the genus *Methanosarcina* can use all 3 routes to methane.

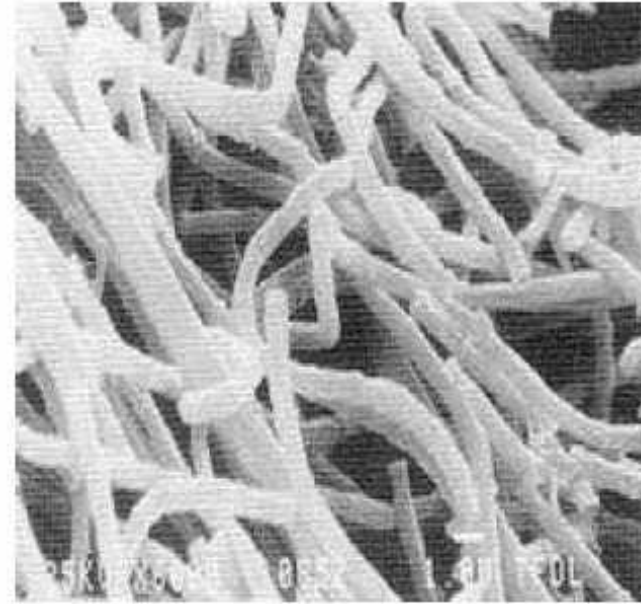

Scanning electron micrograph of archaea from the genus *Methanosaeta*. Members of the genus *Methanosaeta* are acetotrophic, i.e. they produce methane from acetate.

Image source: Dr L. Hulshoff and Professor van Lier; Sub-department of Environmental Technology, Wageningen University, Netherlands

Normal Process (with methanogenesis)

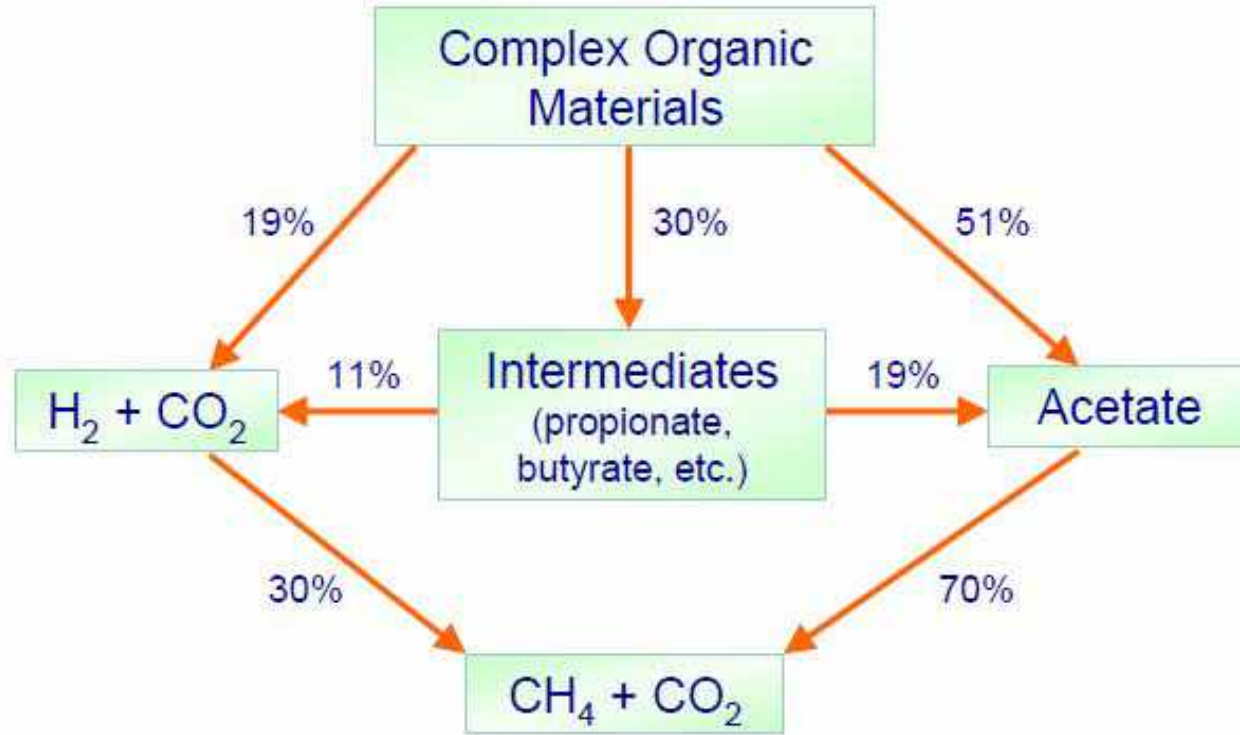

Carbon flow in anaerobic environments with active methanogens



Marmara
Üniversitesi



Process with inhibited methanogenesis

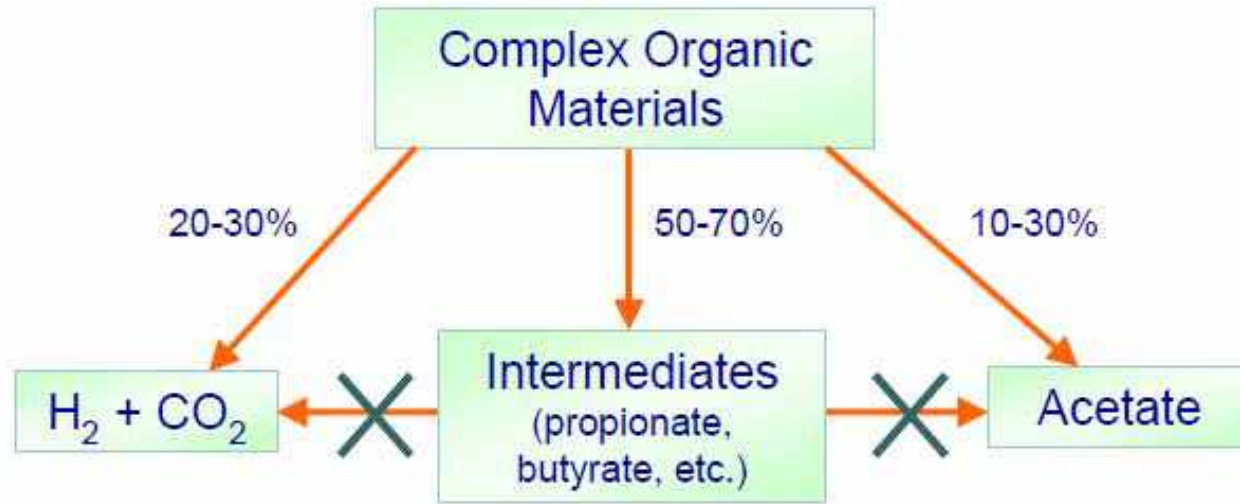

X: Inhibited because of high H_2 partial pressure

Carbon flow in anaerobic environments without active methanogens



Marmara
Üniversitesi



Different requirements for optimum activity of each group

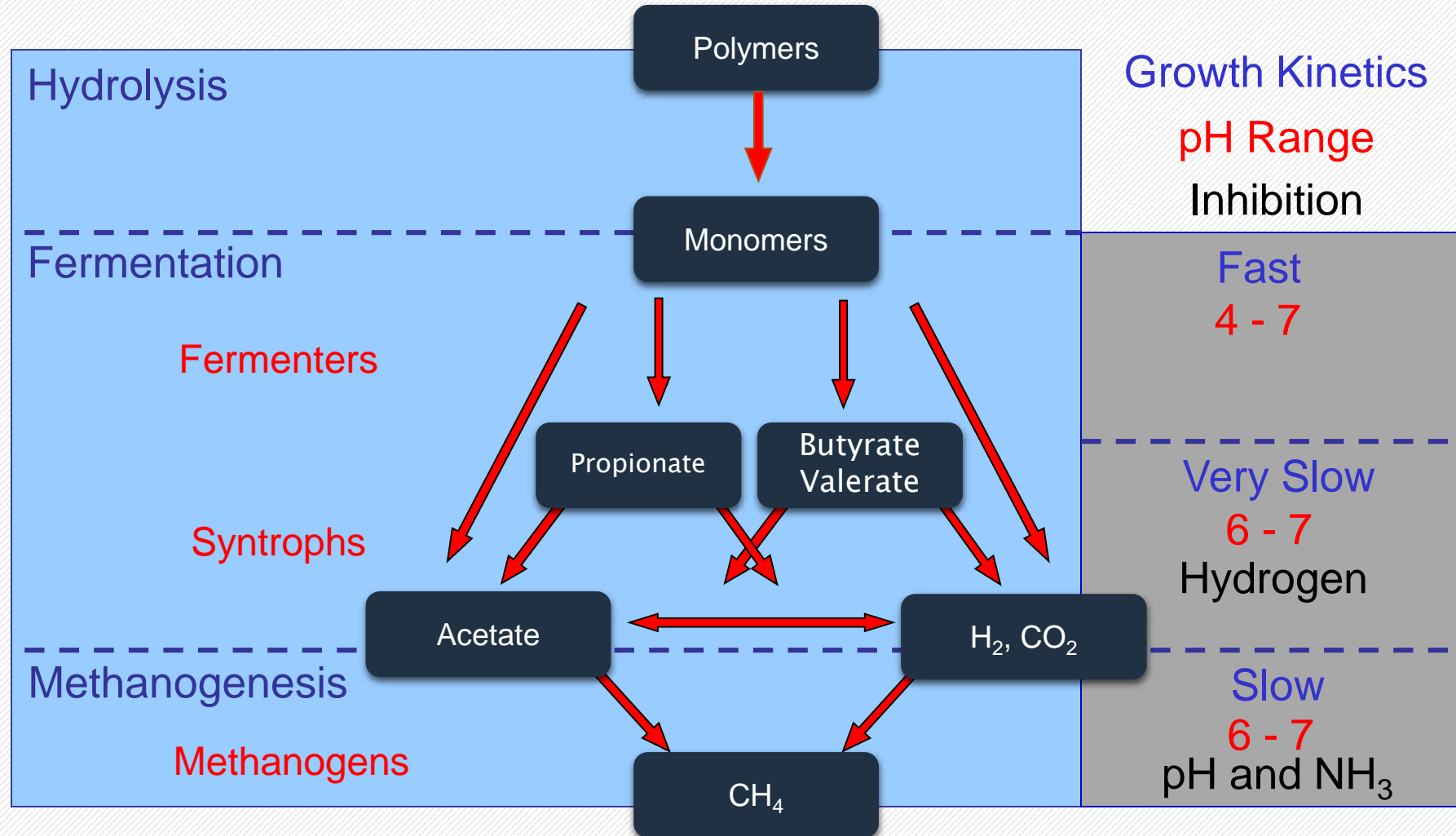

Part 503 Requirements

What is 40 CFR Part 503?

- Standards for the Use or Disposal of Sewage Sludge
 - Establishes operational standards for pathogen and vector attraction reduction for land application
- Different “classes” of biosolids have different requirements
 - Class A and Class B – based on pathogen reduction
 - Other parameters for vector attraction reduction and metals



“Class A” vs “Class B”

- Exceptional Quality (EQ) Biosolids
 - Low Pollutant (Metal) Concentrations
 - Class A Pathogen Reduction
 - 1 of 8 Vector Attraction Reduction Options
- Pollutant Concentration (PC) Biosolids
 - Low Pollutant Concentrations
 - Class B Pathogen Reduction and Site Restrictions
 - 1 of 10 Vector Attraction Reduction Options

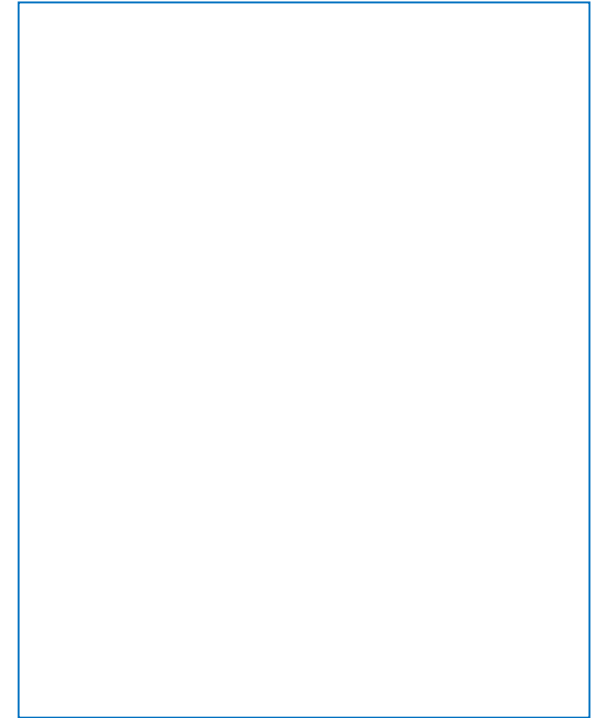

Anaerobic digestion produces biosolids that meet Part 503 requirements

- Reduces volatile solids by at least 38% → Reduces vector attraction
- Significantly reduces pathogens
 - Mesophilic digestion (95°F for 15 days MCRT) → Class B
 - Advanced thermophilic digestion and thermal hydrolysis/digestion reduces pathogens further → potentially reaching Class A
- Does not reduce metals, but historically not an issue for land application

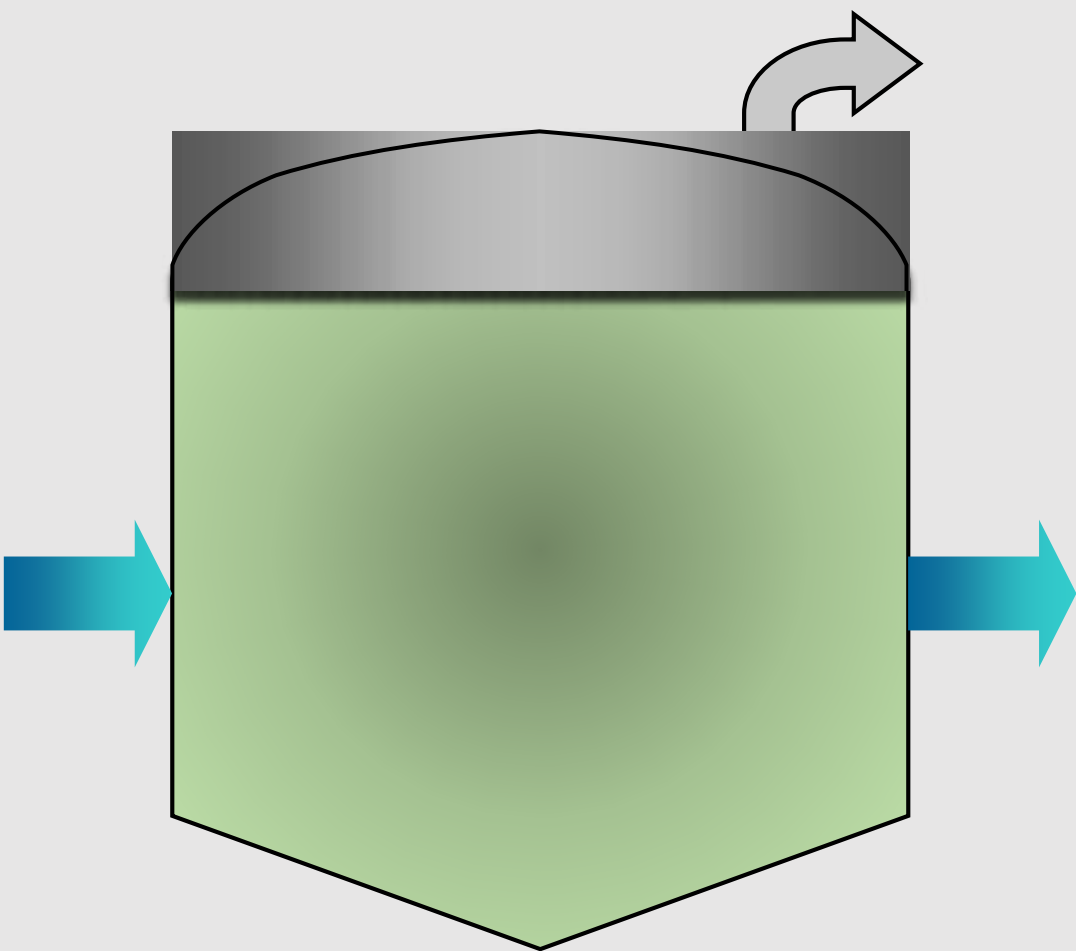

Process Fundamentals

Conventional Mesophilic Anaerobic Digestion

- Acid and methane formers live and compete in same mesophilic temperature tank
 - Design to maintain balance between organisms
 - Rate limiting design criteria for methanogen population
 - Mesophilic temperature ~ 95 degrees F (35 degrees C)

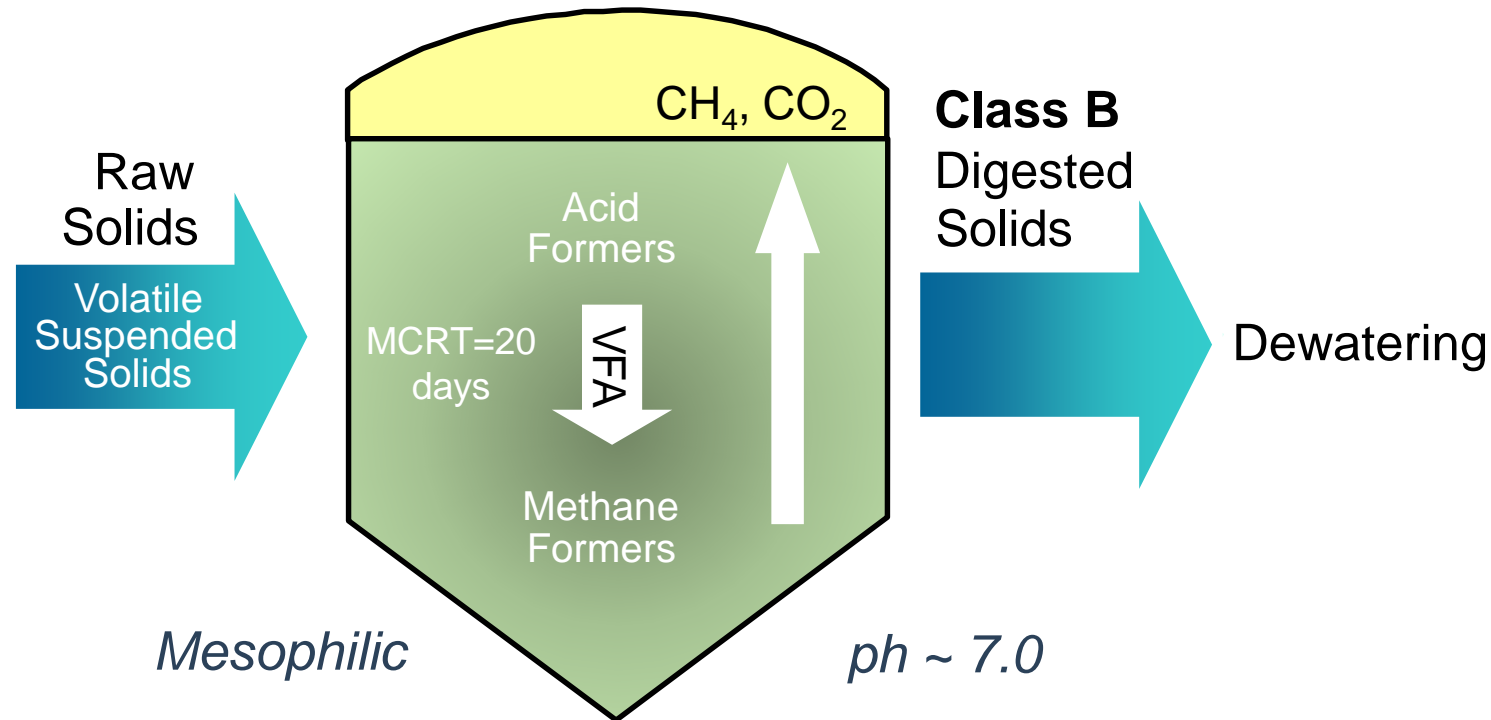

Conventional Mesophilic Anaerobic Digestion Typical Operating Parameters

Parameter	Typical Operating Parameters
Temperature, degrees F	95 to 100
pH	6.8 to 7.4
Solids Retention Time, days	15 to 30
Volatile Solids Loading Rate, lb VS/cf-day	0.08 to 0.16 (dependent on mixing)
Feed Solids Concentration, %	3 to 5
PS:TWAS Percent in Feed	40:60 to 60:40

Conventional Mesophilic Anaerobic Digestion Typical Performance

	Volatile Solids Reduction, %	Avg. Specific Digester Gas Production, cf/lb VS Reduced	Biosolids Quality
Typical Conventional	38 to 55	8 to 15	Class B

Volatile Solids Loading Rate

- Solids Feed Rate → $\frac{\text{gallon}}{\text{min}} \times \frac{8.34 \text{ pounds}}{\text{gallon}} \times \%TS \times \frac{60 \text{ minutes}}{\text{hour}} = \frac{\text{pounds}}{\text{hour}}$
- Volatile Solids (VS) Feed Rate:
 - Solids Feed Rate x VS Concentration of Feed
 - *lb VS/hour or lb VS/day*
- **VS Loading Rate (aka Organic Loading Rate)**
 - $VSLR = VS \text{ Feed Rate (lb VS/day)} / \text{Digester Volume (cf)}$
 - *lb VS/cf/day*
 - Typically 0.08 to 0.16 lb VS/cf/day
 - Lower values equate to higher retention times, higher values require good mixing

Solids retention time or hydraulic retention time?

- For “flow in = flow out” system (no recycling):
solids retention time (SRT) = hydraulic retention time (HRT)

$$\text{HRT (days)} = \frac{\text{Digestion Volume (gallons)}}{\text{Feed Flow (gpm)}} * \frac{1 \text{ day}}{1440 \text{ min}}$$

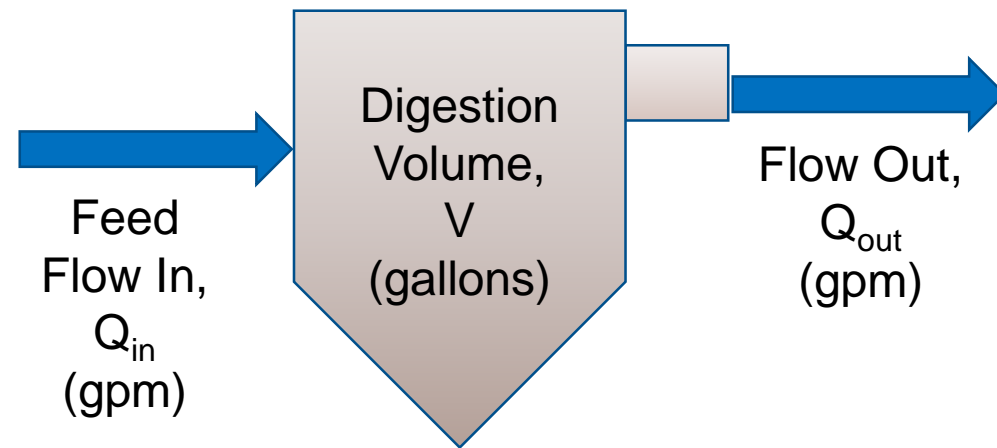

Digester Sizing

- Determine minimum SRT required at maximum month or maximum week sludge flows (projected)
 - If Class B sludge, must meet Part 503 requirements
 - 15 days
 - If not constrained by regulatory requirement, can base on methanogens and avoiding washout
 - ~12 days
 - Remember to account for all feeds
 - Primary solids, primary scum, secondary solids, external food waste

Digester Sizing

- Maintain sustainable VSLR at projected maximum month or maximum week solids loads or... 
- Remember to consider downtime
 - Taking digesters out of service for cleaning, maintenance and repair



Configurations

Conventional Mesophilic Digestion (Class B)

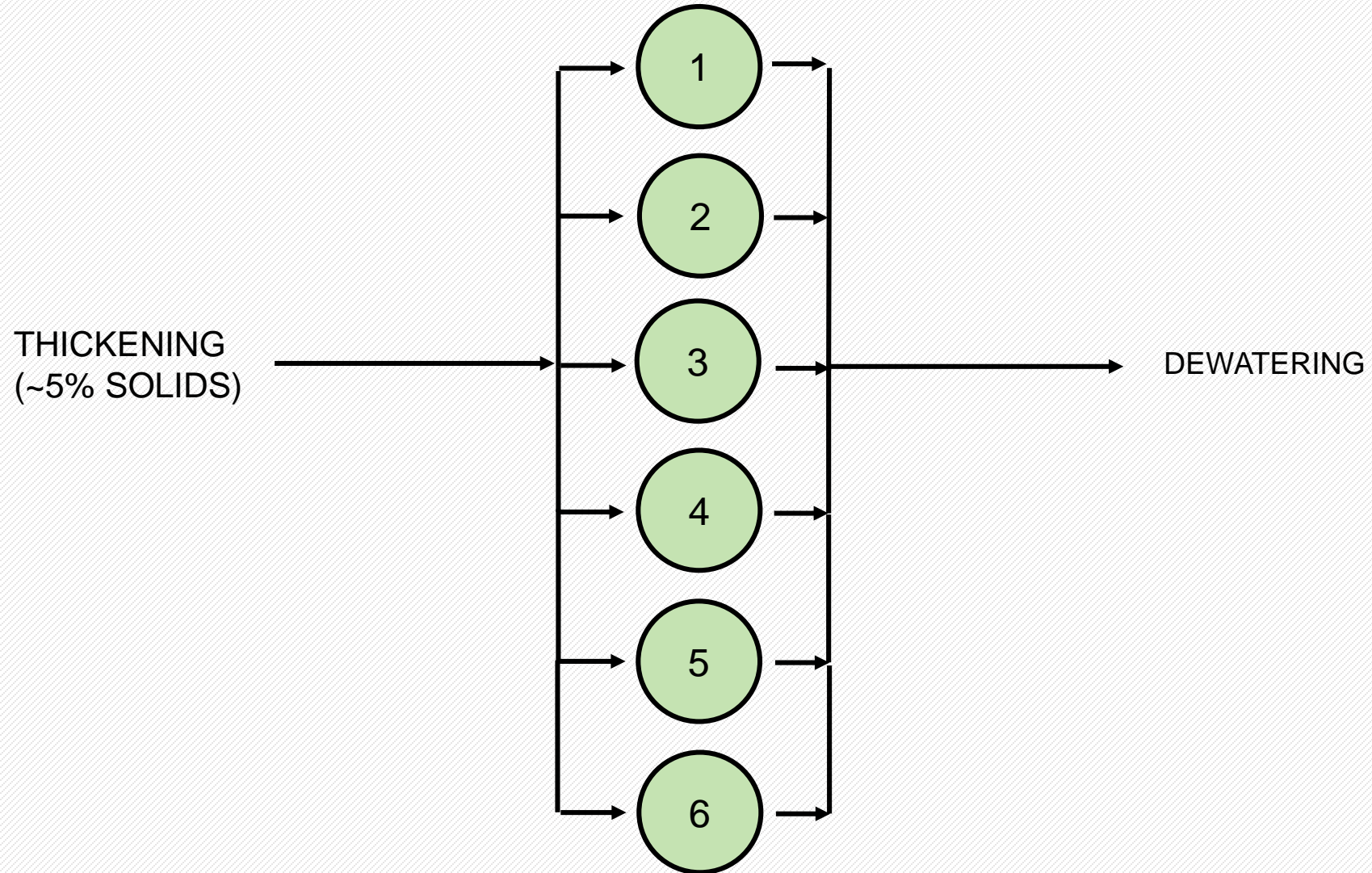

Conventional Mesophilic Digestion (Class B)

- Widely practiced

ADVANTAGES	DISADVANTAGES
<ul style="list-style-type: none">• Familiar, proven process• Existing infrastructure/equipment• Smaller heating system sufficient for mesophilic operation• Lower O&M than advanced	<ul style="list-style-type: none">• Solids limited = larger volume req'd for additional load• Suboptimal environment for competing organisms• Process can become unstable if environment changes• Can be overloaded with FOG/Food Waste addition or shock loads• Longer SRT required to achieve same VSR as advanced• Longer SRT required to achieve same gas production as advanced• Class B biosolids produced• Parallel feed requires complex controls/valves

In conventional digesters all microbial groups co-exist with the same environmental conditions

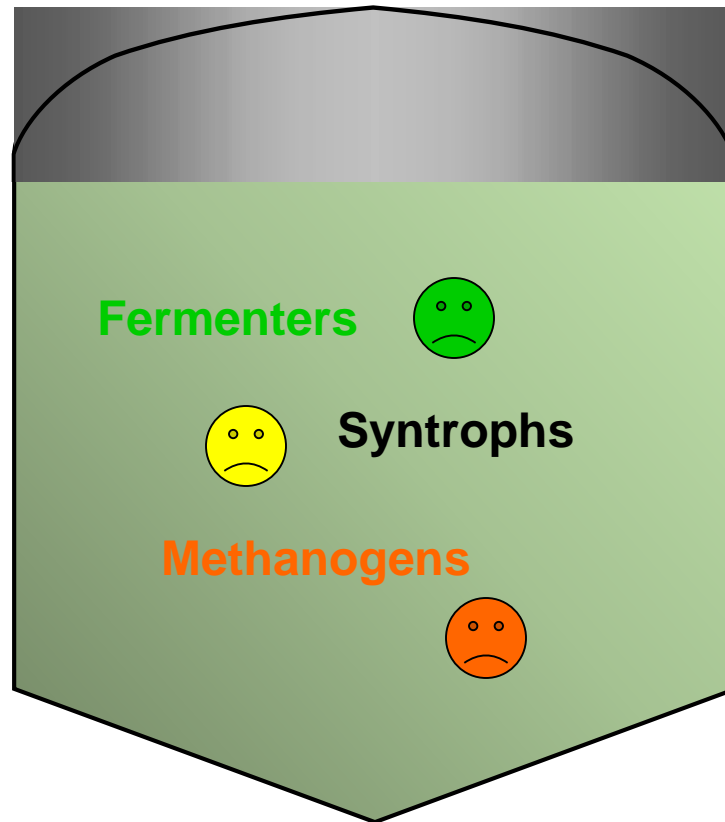

Acid Phase Digestion (Class B)

- Acid and methane formers live and thrive in separate tanks
 - Acid phase - short SRT, highly loaded
 - Methane phase tank sized for methanogens

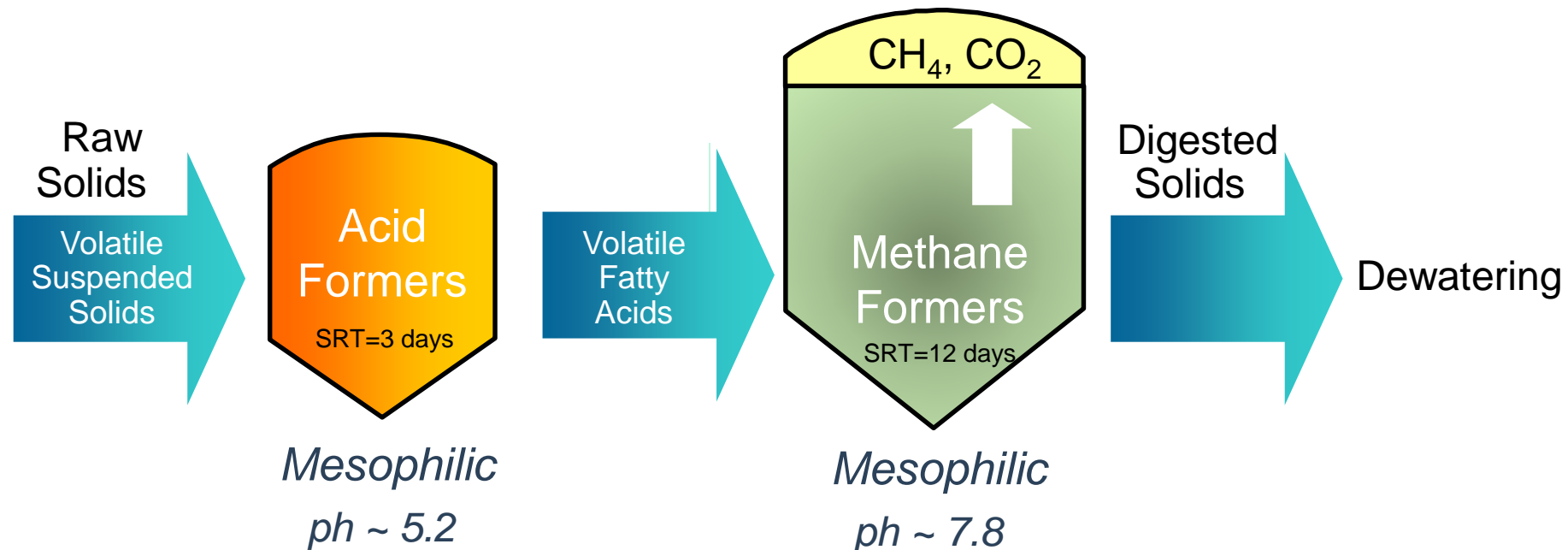

Acid Phase Digestion (Class B)

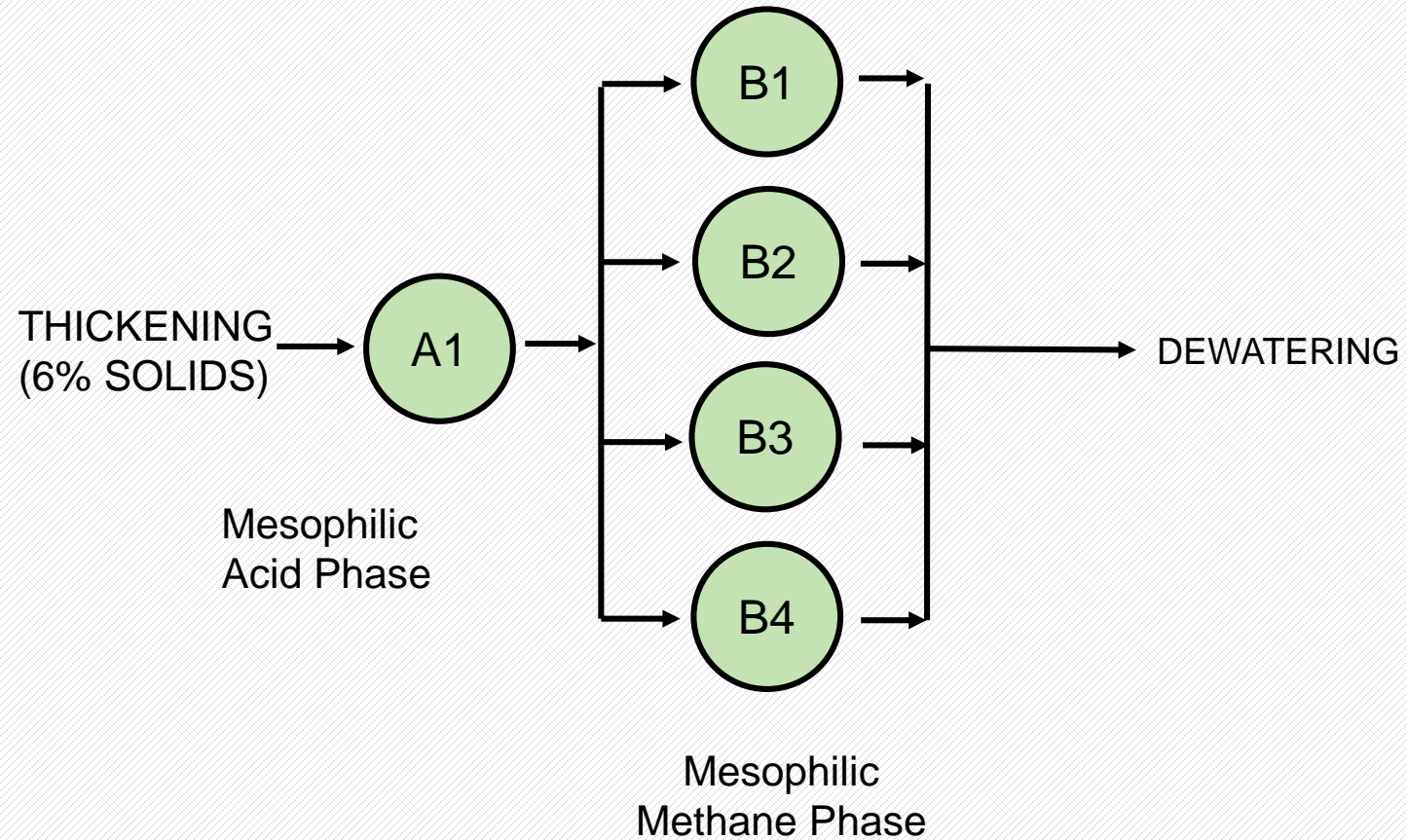

Acid Phase Digestion (Class B)

ADVANTAGES	DISADVANTAGES
<ul style="list-style-type: none">• High VS loading rate = smaller volume req'd• Single feed point for digestion = fewer valves/simpler control• Process stability of methane phase significantly improved• Easier to feed and more robust for FOG/food waste/shock loads• Less susceptible to temperature changes than thermophilic• Shorter SRTs to achieve same or better VSR than conventional• Improved biogas production/quality• Better hydrolysis of biological sludge• Reduced solids to dewatering• Heat requirements for mesophilic• Potentially reduced foaming	<ul style="list-style-type: none">• Can become unstable if insufficiently loaded and mixed or SRT too long• Acid gas quality = Low BTU• Hydrogen sulfide in acid gas• Odorous sludge if exposed• High ammonia load in recycle• Class B• Larger heat exchanger(s) required for acid phase• More complex O&M for two phases• New piping between phases• Less widely practiced than conventional

Temperature Phased Anaerobic Digestion TPAD (Class A)

- Thermophilic temperatures ~ 122-133°F (50-56°C)
 - Thermophilic phase increases hydrolysis/digestion rates
- Mesophilic phase reduces VFAs/odors

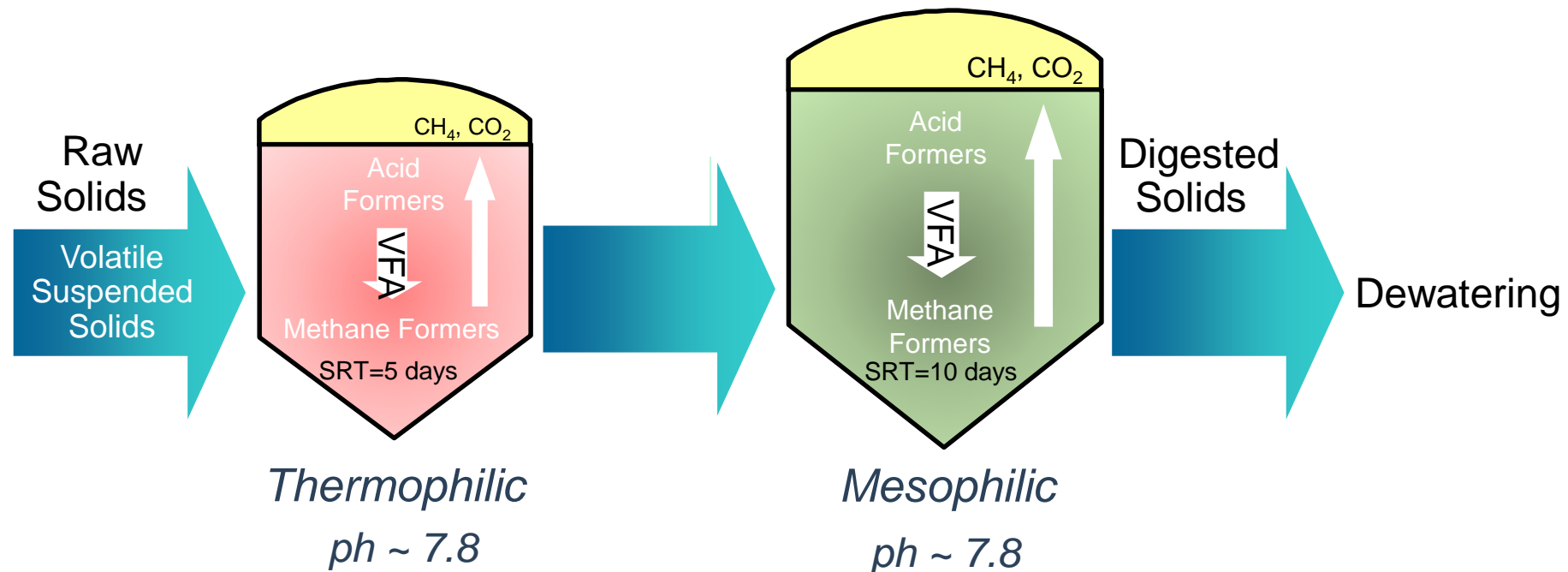

Temperature Phased Anaerobic Digestion TPAD (Class A)

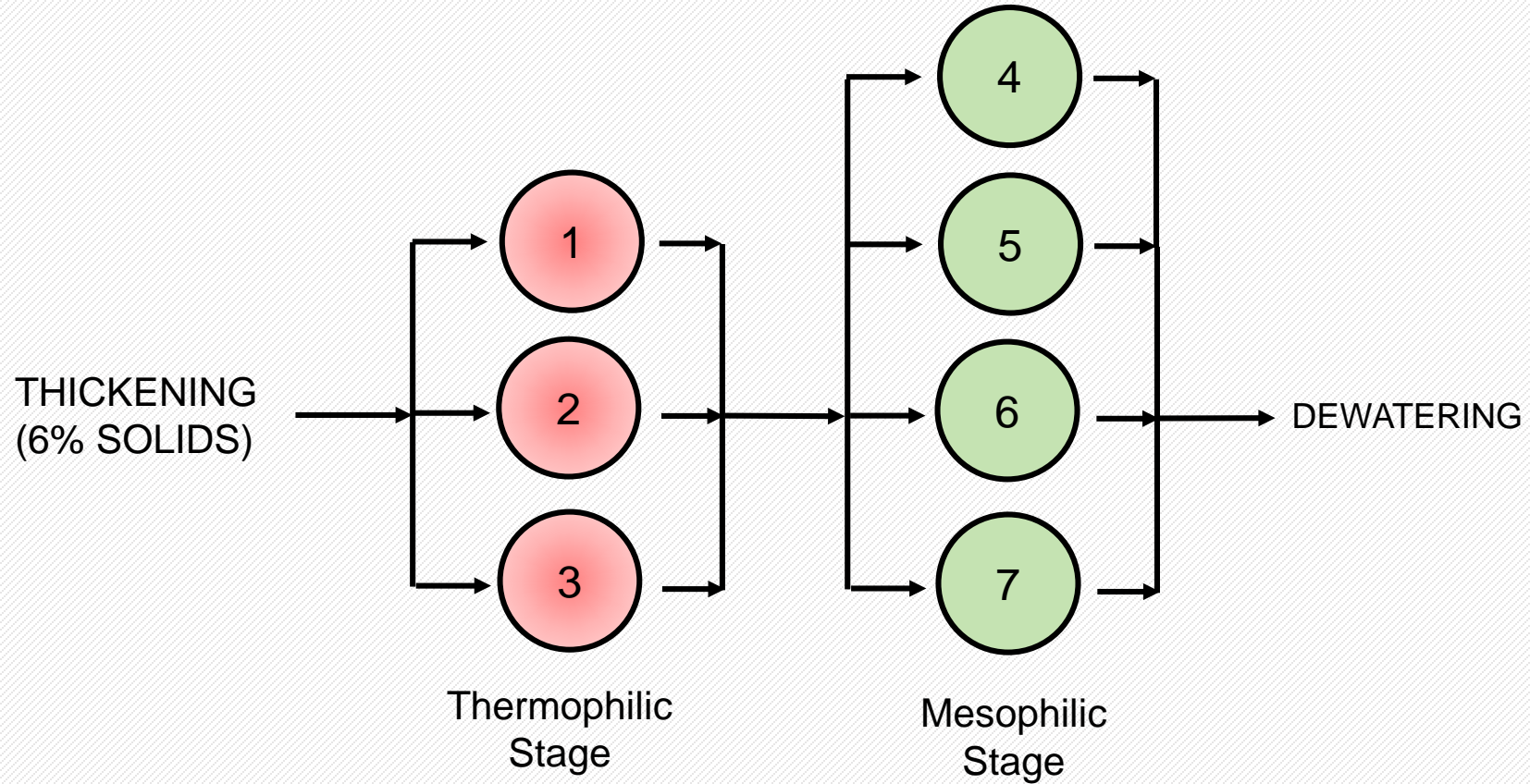

Temperature Phased Anaerobic Digestion TPAD (Class A)

ADVANTAGES	DISADVANTAGES
<ul style="list-style-type: none">• Class A biosolids produced• High VS loading rate• Higher VSR at short SRTs• Better hydrolysis of biological sludge• Reduced solids to dewatering• Lower odors in dewatering/filtrate than thermo only	<ul style="list-style-type: none">• Requires larger heat exchangers/heating system (more energy)• First phase highly susceptible to temperature changes• Poor dewaterability• High ammonia in thermo phase sludge• Struvite/vivianite formation• Moisture content in biogas• Parallel feed requires complex controls/valves• Higher O&M for multi-phase• Testing for Class A

Polling Question

- Which of these statements is true?
 - a) Class B biosolids require a 20 day retention time.
 - b) Methanogenesis is the last stage of digestion.
 - c) Volatile solids loading rate is not a critical operating parameter.
 - d) Thermophilic digesters operate at a cooler temperature than conventional digesters.

5 Minute Break



WWOA would like to thank our generous sponsors and partners for their support of our mission to provide training and education opportunities for our members and others working in the water and wastewater profession.

2020 WWOA Virtual Operator Training Series

Accessible ~ Affordable ~ Informative

Anaerobic Digestion Virtual Operator Training ~ May 6, 2020

PRESENTING SPONSOR:



CONTRIBUTING SPONSORS:



Operations

Sludge Feeding and Loading

Feeding

- **Feeding** = physical transfer of sludge to the digester without taking into consideration the volume of contents of the digester
 - Frequency of feeding:
 - Once per day (worst possible procedure)
 - Continuous feed at a low rate (best feed schedule)
 - Frequent feeding for short intervals (next best alternative)
 - Large shock loads can result in fluctuations of gas production, pH, alkalinity, organism growth rate, volatile acids concentrations, etc.
 - Large fluctuations can cause digester failure
 - If there are multiple primary digesters it is essential that each receives an equal volume of feed daily.

Loading

- **Loading** = Loading considers the feeding in relation to the contents and volume of the digester
- Organic loading rates for a well-mixed and heated digester range from 0.1 to 0.2 lb VS/day/ft³
 - In order to calculate loading, a record must be kept of the mass (lb) of volatile solids per day being fed to the digester and the digester usable volume (i.e., the capacity of the digester)
- **Example**: A new digester has a 50-ft diameter with a sludge depth of 33-ft. If 25,000 gal/day of 5% sludge with a volatile solids content of 84% is added per day, what is the volatile solids loading on the digester?

Example Answer

$$\text{Volatile Mass Load} = 0.025 \text{ mgd} \times 50,000 \frac{\text{mg}}{\text{L}} \times 8.34 \times 0.84 = 8,757 \frac{\text{lb VS}}{\text{day}}$$

$$\text{Digester Volume} = \frac{\pi \times (50\text{ft})^2}{4} \times 33\text{ft} = 64,795 \text{ ft}^3$$

$$\text{VS Loading} = \frac{8,757 \frac{\text{lb VS}}{\text{day}}}{64,795 \text{ ft}^3} = 0.135 \frac{\text{lb VS}}{\text{day} \cdot \text{ft}^3}$$

What happens if the digester is not operated and maintained well and grit is allowed to accumulate to 10-ft depth and there is a static scum layer 2-ft thick?

Sludge Feed Control

- Pumped loop of sludge feed (PS, WAS, Scum, etc.)
- Dedicated feed line, meter, and automated valve at each digester
- Feed each digester for time or volume every hour (or so) – stable feed critical
 - Optimal feed is a stable blend of primary sludge and WAS, continuously fed
- Control VSLR and SRT
- Remember PS:WAS ratio should also be consistent
 - (changes in the PS:WAS ratio changes the VS content)





Mixing

Types of Digester Mixing

- Gas
- Mechanical
- Natural (i.e., no mixing)

Multiple digester mixing technologies available



Effective digester mixing is key for proper AD performance

- Prevents stratification and promotes good contact between feed sludge and bacteria
 - Provides even distribution of contents throughout the digester
 - Ensure that no short circuiting occurs
 - Enables chemicals added for pH control to be evenly distributed
- Minimizes grit settlement and accumulation
- Reduces the effects of toxic substances by promoting rapid dispersion and dilution
- Provides uniform temperature in the digester
- Minimizes scum accumulation, foaming and/or rapid rise
- Increases gas release

Digester Mixing

- Energy Input
 - Brake horsepower/digester volume
 - Typical range 0.2 to 0.3 bhp/1000 ft³
- Turnover Rate
 - Amount of time it takes for the pumped/mixed flow to turn the digester volume over completely
 - 20 to 30 minutes for draft tubes
 - 3 to 4 hours for pump mixing
 - Equivalent to 30 min turnover due to nozzle-entrained flow which creates secondary flow within tank

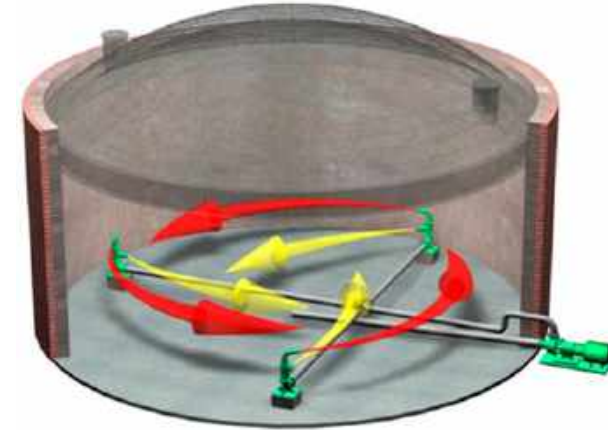

Digester Mixing

- Assessing effectiveness
 - **Temperature profile** with temperature readings at fixed depth intervals and across tank (not too expensive and fairly simple)
 - Variation from average of more than 1 to 2 °F indicates poor mixing
 - **Coefficient of Variation of solids samples** at 2-ft depth intervals and across tank (a bit more expensive and time consuming)
 - $Cv = (\text{standard deviation of all samples}) / \text{mean of all samples}$
 - If $Cv > 10\%$ mixing is poor
 - **Tracer studies** (expensive, time consuming and interpretation of results is cumbersome)



Heating

Importance of Digester Heating

- Methane forming microorganisms are temperature sensitive
 - Maintaining constant digester temperature is one of the most important operator controlled functions
 - Requires a reliable, well maintained and well-understood heating system
 - Mesophilic range 32-38°C (90-100°F)
 - Thermophilic range 55-60°C (131-140°F)
- Digester Contents should not deviate by more than 0.6°C (1°F) per day

Specific Gas Production as a Function of Temperature

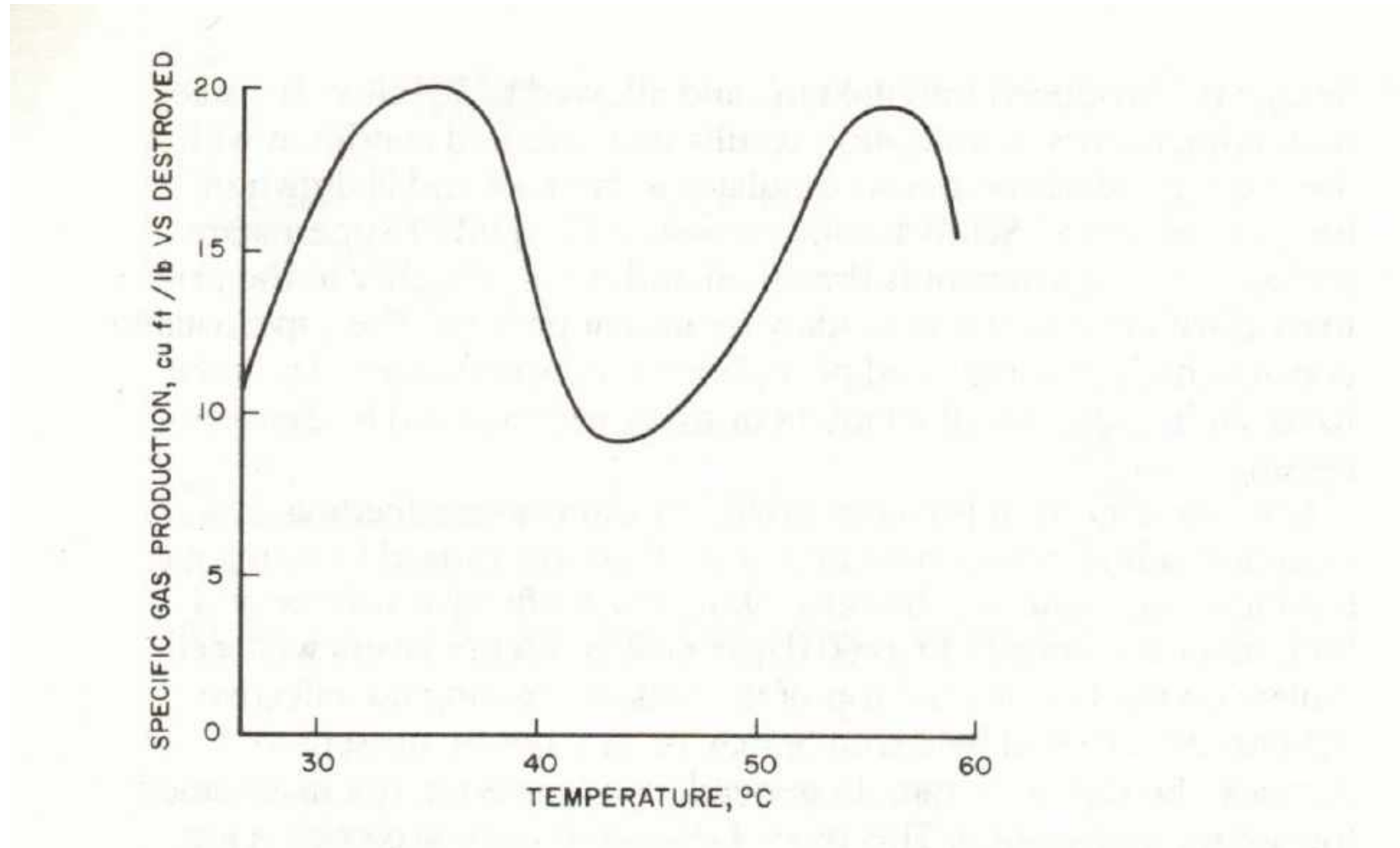

Digester Heating

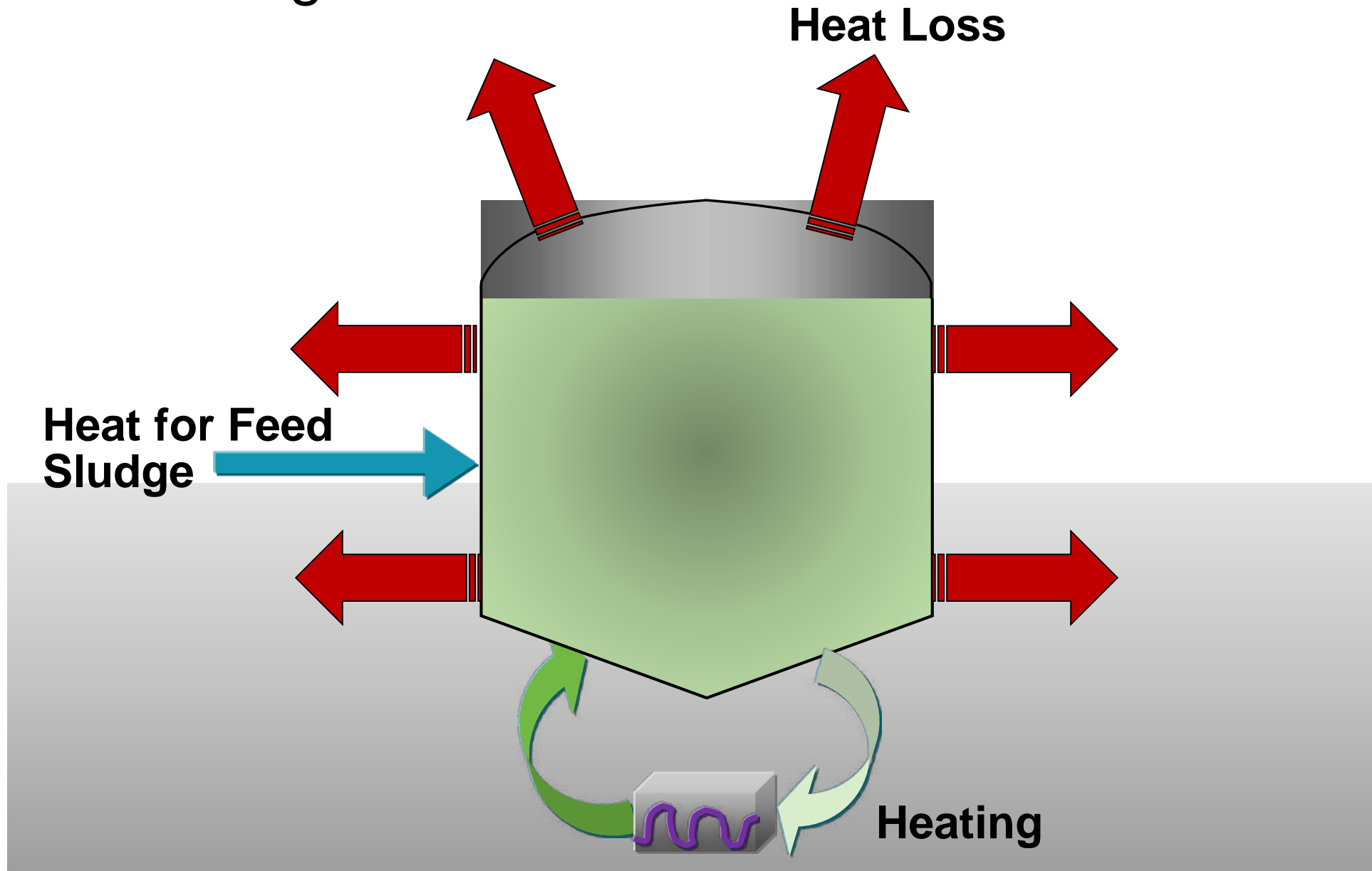

Digester Heating

- Total Heat Requirement = Sludge Heating + Transmission Losses
 - Sludge Heating – heat required to raise the temperature of the incoming sludge
 - Transmission losses – heat required to make up losses from the digester to its surroundings
- Account for:
 - Max Loading
 - Winter and Summer Temps
 - Different Materials and U values
 - Different Surrounding Materials/Environments
- Summer must be considered for heat supply turndown

Simplified Hot Water System Schematic

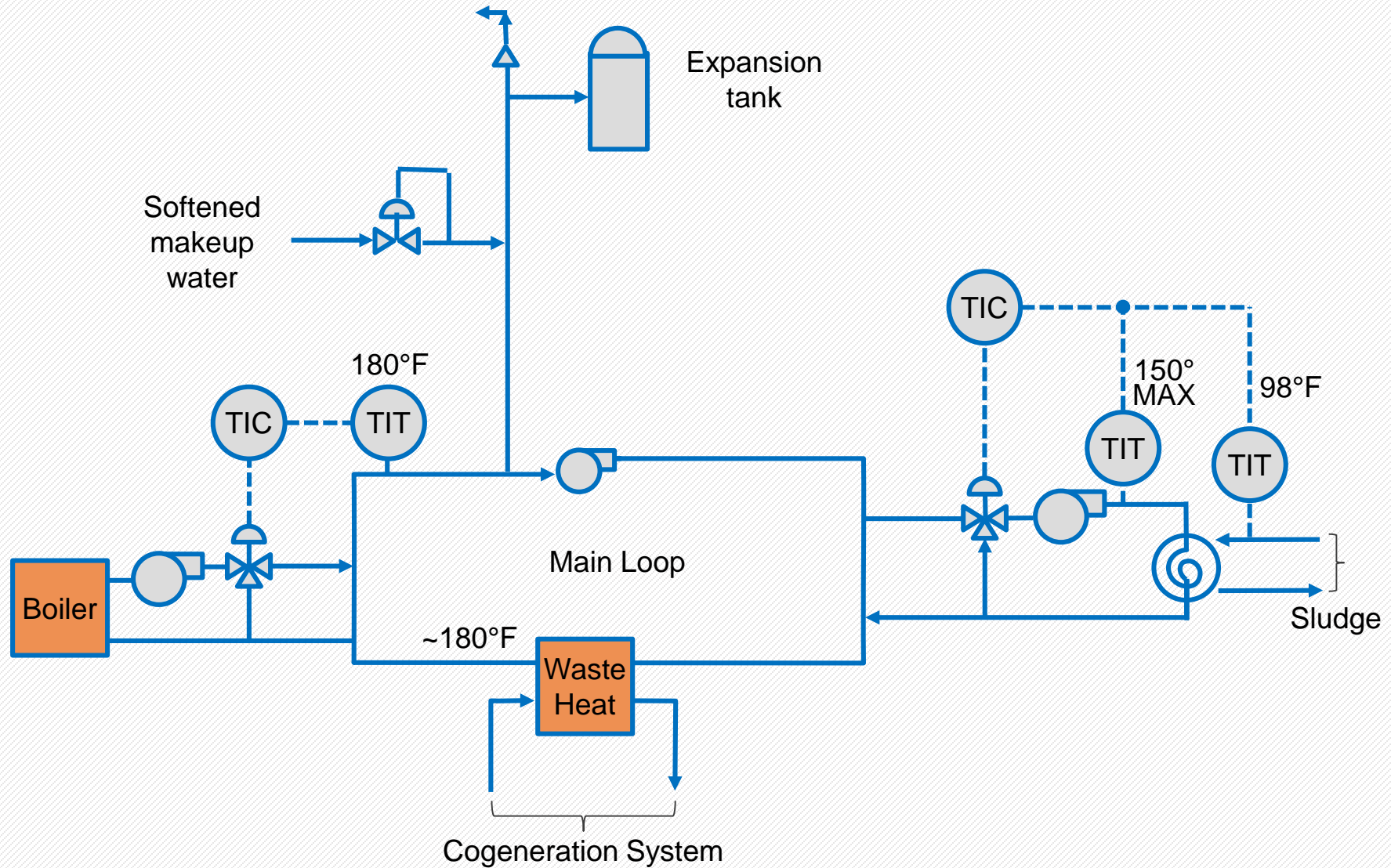

Sludge Recirculation Schematic

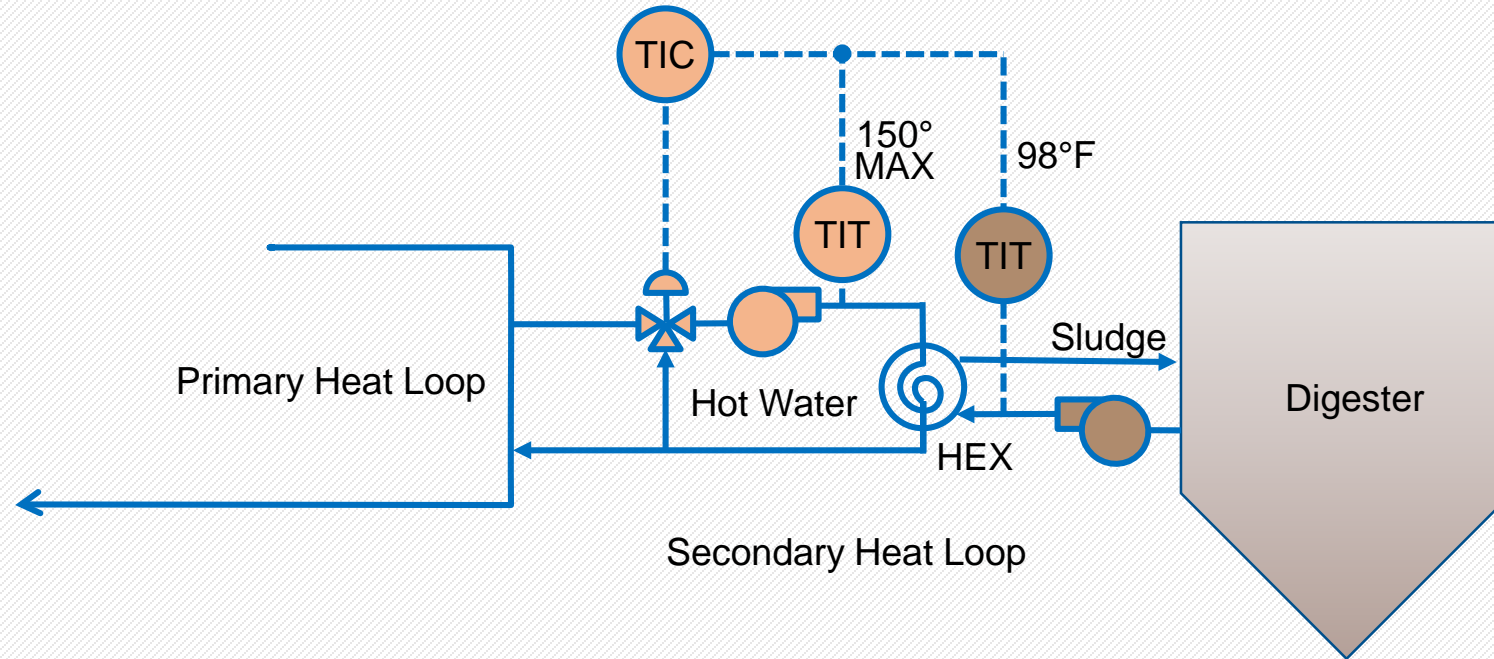

Typical Hot Water System Components

- Pumps
- Air separator
- Expansion tank
- Makeup water connection
- Chemical feeder
- Air relief valves
- Control valves
- Balancing Valves
- Strainers
- Pressure relief valves
- Boilers
- Valves
- Heat exchangers

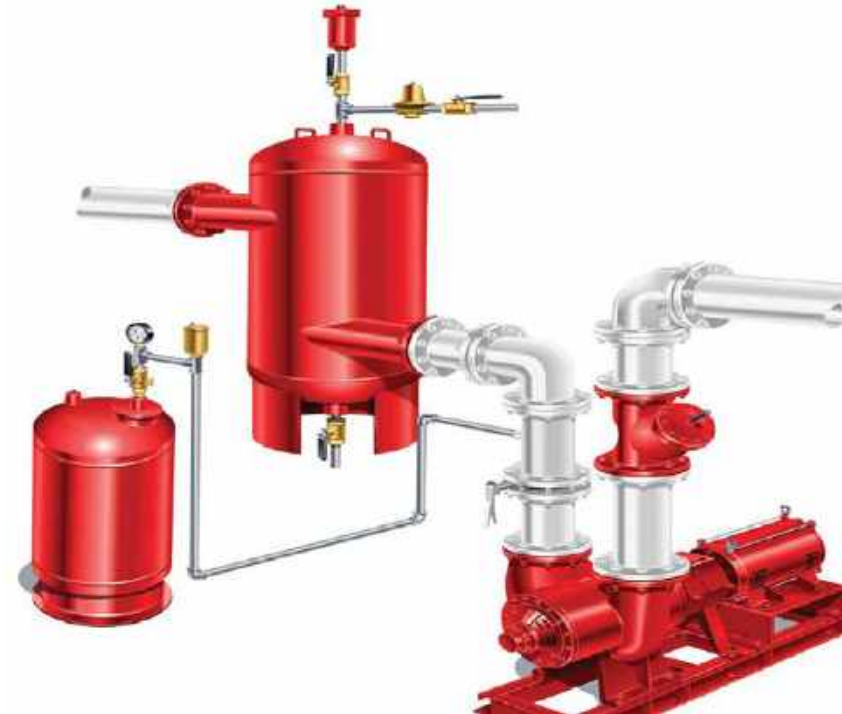

Heat exchanger characteristics should balance performance with O&M requirements



**Transfer
Efficiency**

Footprint

Ragging

**Operator
Friendly**

**Full-scale
Experience**

Hot Water Systems

- Problem: Corrosion
 - Air intrusion
 - Poor water treatment
 - Solution: Chemical feeder in hot water system
 - Oxygen scavenger
 - Biocide
- Problem: Scaling
 - Solution:
 - Use water softener for all make-up water
 - Scale inhibitor



Heat Exchanger Scale – Baked on Sludge, Vivianite, Struvite



Prevention and planning can prevent scaling problems

- Mitigation involves removing conditions that favor scaling:
 - Treat water
 - Remove phosphorus
 - Prevent large temperature changes
 - Prevent large pH changes
 - Remove formation potential sites
- Avoid overheating sludge



Digester Gas Systems

Digester Gas Systems

- Digester Gas Characteristics
 - Fully saturated (moist gas)
 - CH₄, CO₂, H₂S, particulates, siloxane, foam

TABLE 30.2 Physical and chemical properties of methane.

Physical characteristics	Colorless, odorless
Specific gravity	0.55 at 21 °C (70 °F)
Density	0.042 kg/m ³ at 21 °C (70 °F)
Hazard	Extremely combustible
Flammability limits in air	Forms an explosive mixture with air (5 to 15% volume). Avoid naked flames or spark-producing tools when there is unburnt gas in the air.
Toxicity	Asphyxiant at high concentrations (causes insufficient intake of oxygen)
Typical heating value	37 750 kJ/m ³ (1016 Btu / cf) (natural gas) Biogas has a lower heating value of 22 400 kJ/m ³ (600 Btu / cf) because it typically contains only 60 to 65% methane.

Digester Gas Systems

- Digester Gas Characteristics
 - Requires conditioning before use
 - Compression
 - Moisture removal
 - Particulate removal
 - Hydrogen sulfide removal
 - Siloxane removal
 - It is not common to remove CO₂ for on-site use but is required for injection into gas grid

Digester Gas Characteristics	
Constituent	% by Volume*
Methane (CH ₄)	73 to 75
Carbon Dioxide (CO ₂)	21 to 24
Hydrogen (H ₂)	1 to 2
Nitrogen (N ₂)	1 to 2
Hydrogen Sulfide (H ₂ S)	1 to 1.5
Heat value, Btu/ft ³	739 to 750
Specific gravity (air = 1)	0.70 to 0.80



Digester Gas Systems

- Digesters designed for specific gas pressure and vacuum
- Protective devices on digesters
- Flares for excess gas
- Beneficial use of gas for production of power and heat (cogeneration)
- Gas storage
 - Low pressure (8"-12" WC; 1-2 hours for dampening)
 - High pressure spheres for compressed gas at 80-100 psi
 - Helps with gas utilization equipment control

Digester Gas Systems



Digester Gas Systems

- Materials of Construction
 - Piping typically stainless steel if exposed
 - Buried piping can be HDPE
 - Components on digester can be aluminum or stainless steel
 - Spark-proof materials

Digester Gas Systems

- Important features
 - Redundancy on safety equipment
 - Backup seal/pressure/vacuum relief
 - System ties to allow feed/withdrawal cycles without overpressure/vacuum
 - Sloping piping to condensate collection points
 - Corrosion resistant materials
 - Gas purge points for connection of purge gas and other points for discharge to carbon filter
- Regular monthly inspection and maintenance is crucial to safe operations!

Operating Parameters

Simplified Microbial Pathway of Anaerobic Digestion

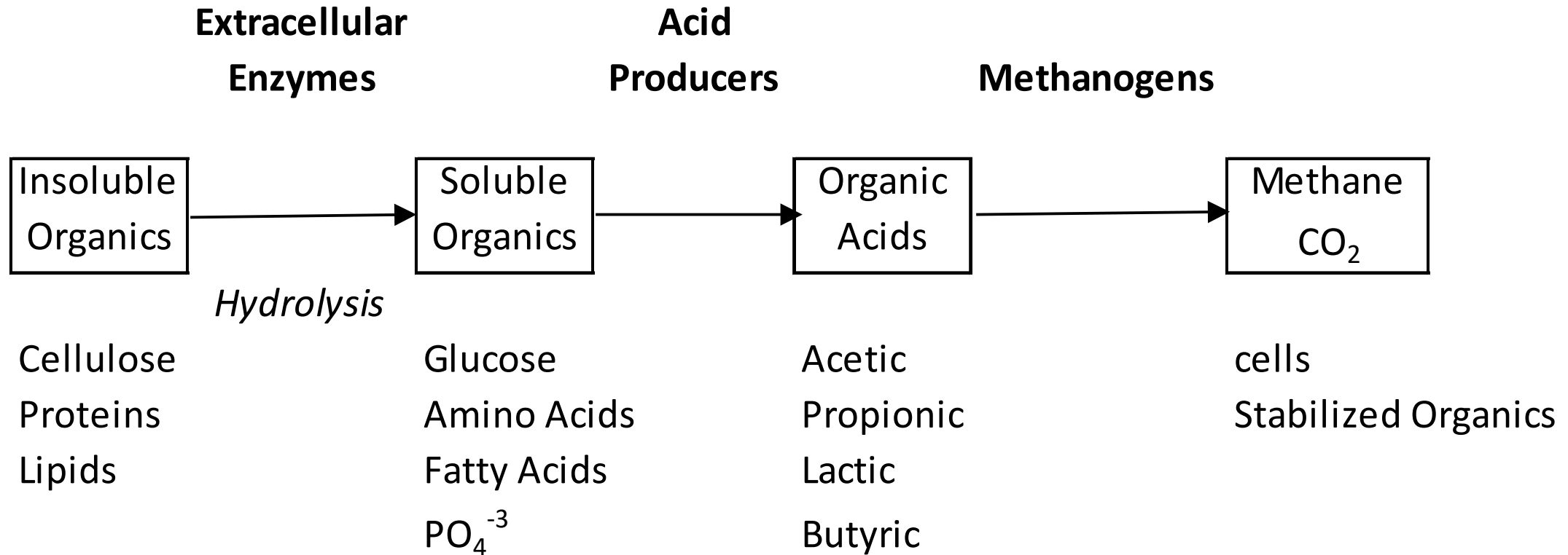

Digester Feed

- Stable feed quantity and characteristics
 - PS, WAS, Scum, External Feedstock, etc.
- Maintain as high a PS:WAS ratio as possible
- Feed concentration between 4-6% TS optimal
 - <4% → too much water, reduction in SRT, increase in heat, inefficient use of digester volume
 - >6% → difficult to mix
- Minimize grit and debris as much as possible

Operational Stability and Digester Monitoring

TABLE 30.7 Digester monitoring table.

Parameter	Units	Test method	Target	Frequency	Sample location	
					Feed sludge	Recirculated sludge ³ or digested solids
Temperature ¹	°C (°F)	Meter	32–38 °C (90–100 °F)	Daily		X
Volatile acids	mg/L	5560C ⁴	50–330	Daily		X
Alkalinity (Alk)	mg/L	2320 ⁴	1500–5000	Daily	X	X
VA :Alk ratio	(none)	Calculated	0.1 to 0.2	Daily	N/A	N/A
pH	pH units	Meter	6.8–7.2	Daily	X	X
Total solids ²	%	2540B ⁴	(record)	Daily	X	X
Volatile solids ²	%	2540E ⁴	(record)	Daily	X	X
Flow ²	Liters (gallons)	Meter	(record)	Daily	X	X
Gas production	cfd	Meter	12 to 16 ft ³ /lb volatile solids destroyed	Daily		Gas system
Gas composition (CO ₂)	%	Gas analyzer	Less than 35% CO ₂	Daily		Gas system

¹Temperatures for mesophilic digesters. Thermophilic digester target temperatures may vary based on design.

²Measure total and volatile solids content and flow separately for all feed sludges.

³Sampled upstream of raw sludge introduction point.

⁴*Standard Methods* (APHA et al., 2005).

Additional Factors

- Avoid inhibition of methanogens:
 - Hydrogen partial pressure
 - Metals
 - Ammonia

TABLE 30.8 Effect of ammonia nitrogen on anaerobic digestion (U.S. EPA, 1979).

Ammonia concentration, as N ^a (mg/L)	Effect
50–200	Beneficial
200–1000	No adverse effects
1500–3000	Inhibitory at pH 7.4 to 7.6
>3000	Toxic

^aNitrogen

Troubleshooting

Causes of Process Upsets

- Most upsets due to:
 - Hydraulic overload
 - Methanogen washout; inability to heat
 - Organic overload
 - Excessive VSLR or too much WAS/difficult substrate
 - Production of too many VFAs – inhibit methanogens
 - Heating issues
 - Reaction rates slowed outside optimal temperatures
 - Toxicity
 - Methanogen inhibition
 - Mixing issues
 - Can cause foaming/rapid rise

Signs of Upset

- Increase in volatile acids
- Reduction in alkalinity
- **Increase in VA:Alkalinity ratio**
- Increase in CO₂ content in digester gas (and decrease in CH₄ content)
- Foaming
- Reduction in pH

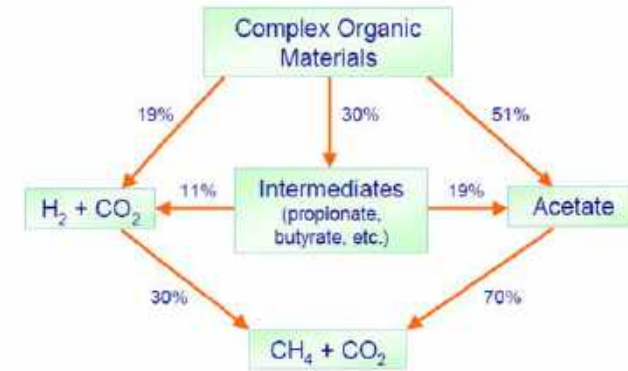

Carbon flow in anaerobic environments with active methanogens



Alkalinity, Volatile Acids, Methane Production, Carbon Dioxide Production, and pH During an Upset

I Relationship Of Volatile Acids To Alkalinity

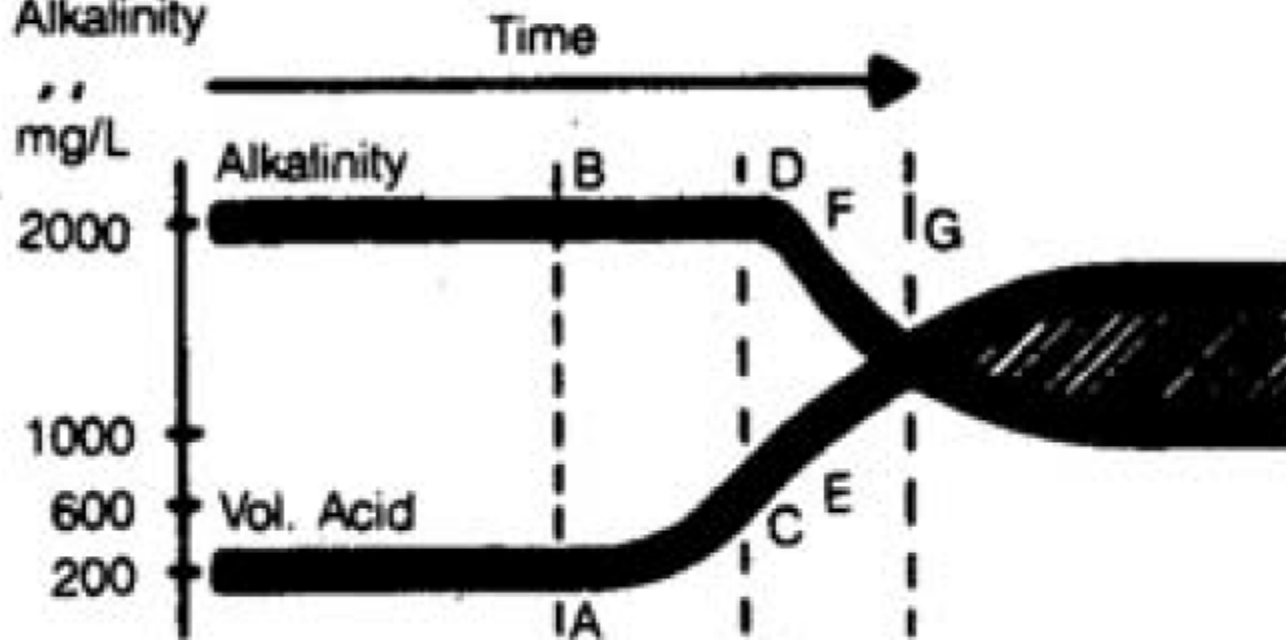

This graph shows a digester operating with a good buffering capacity (low volatile acids 200 mg/L compared to an alkalinity of 2,000 mg/L). At Point A something happens to cause the volatile acids to increase followed by a decrease in alkalinity at Point D. At Point G the digester has become sour.

Alkalinity, Volatile Acids, Methane Production, Carbon Dioxide Production, and pH During an Upset

II Volatile Acids/ Alkalinity Ratio

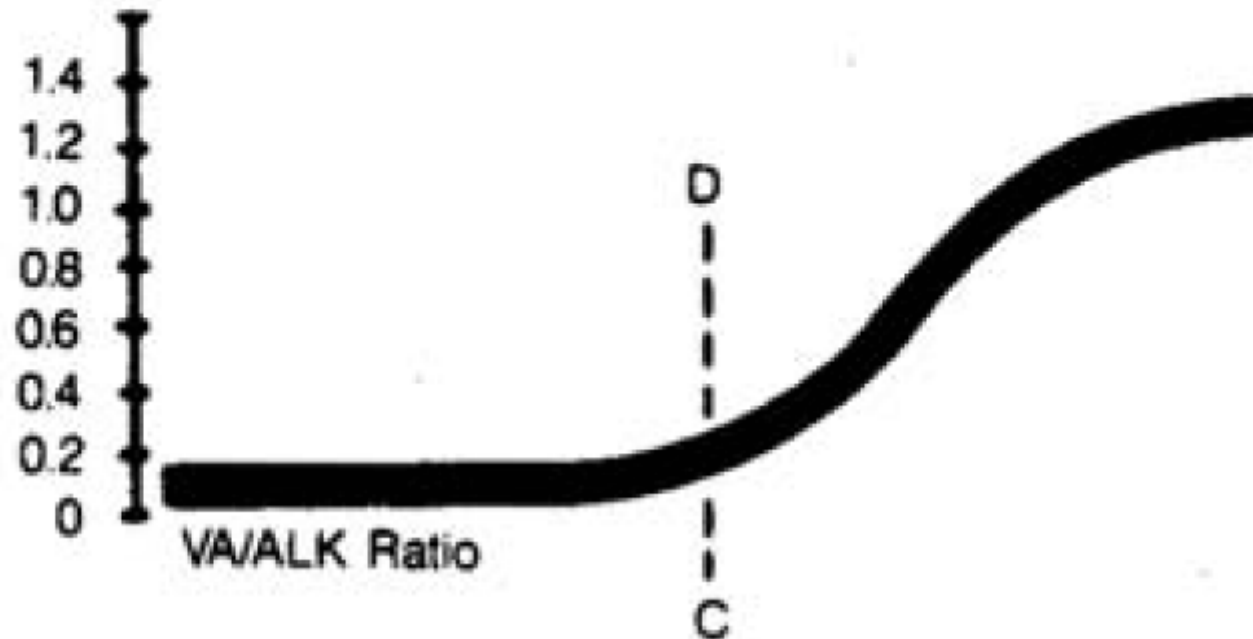

This graph continues the same digester performance by showing the volatile acids/alkalinity ratio. Notice that at Points CD the increase in volatile acids produces an increase in the ratio from 0.1 to 0.3.

Alkalinity, Volatile Acids, Methane Production, Carbon Dioxide Production, and pH During an Upset

III Relationship Of The Change In Ratio of CO₂ To Methane (CH₄) As A Result of "I"

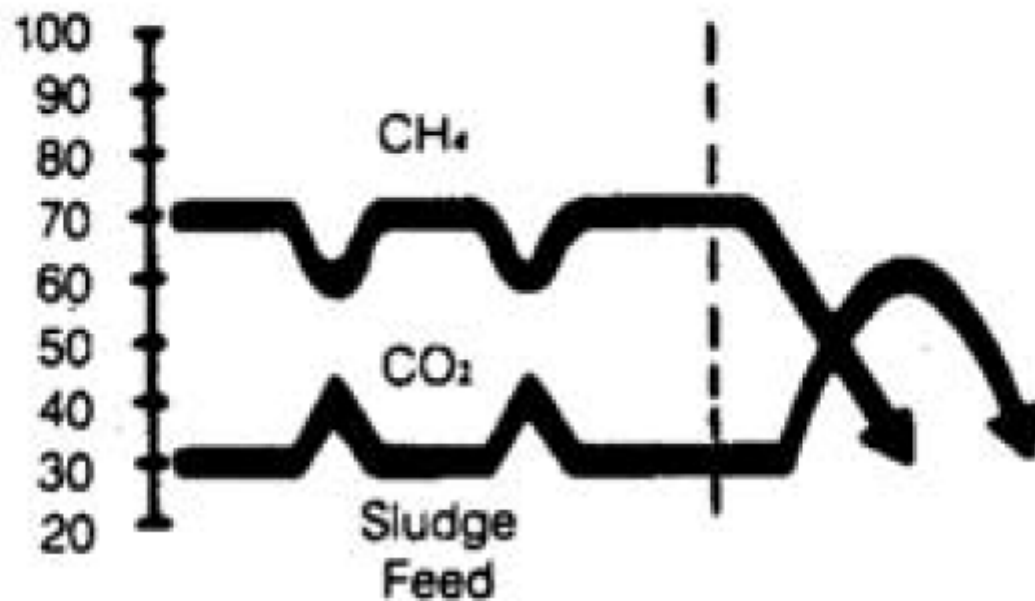

By comparing this graph with Graph II, methane production begins to drop with a corresponding increase in CO₂ when the ratio in Graph II reaches about 0.5.

Alkalinity, Volatile Acids, Methane Production, Carbon Dioxide Production, and pH During an Upset

IV Relationship
Of pH Change To
Change in "I"

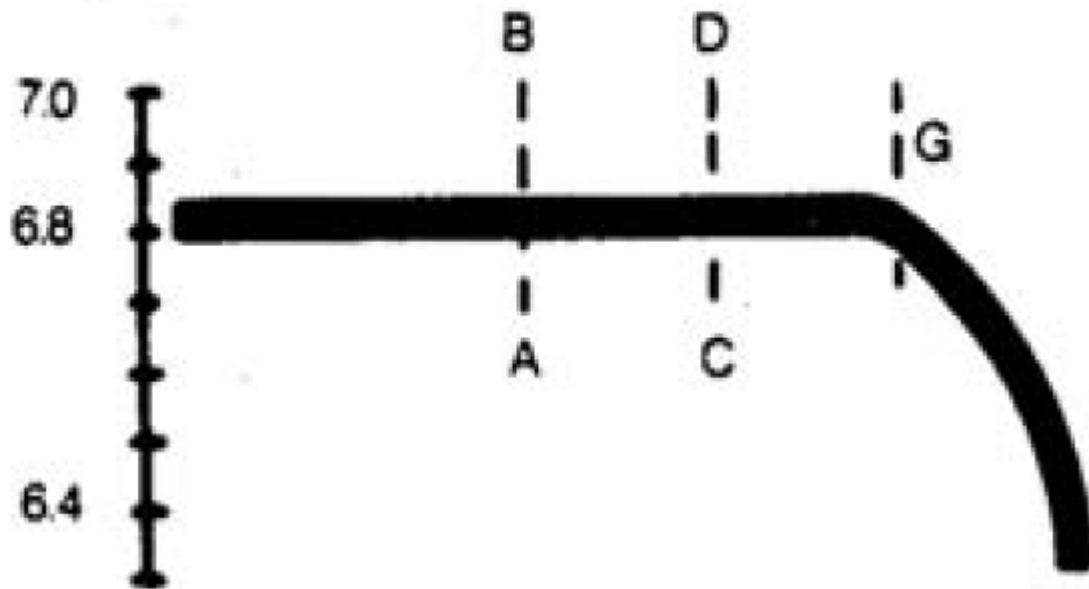

pH doesn't change in this graph until the digester is becoming sour at Point G (too late to react.)

Control Strategies for Upsets

- Stop feeding upset digester (or reduce feed)
 - Monitor pH, alkalinity, and volatile acids
 - Digester may self-correct if upset not full-blown
- Correct the cause of the imbalance
- Provide pH/alkalinity control until treatment returns to normal
- If only one digester (of multiple units) is affected, the loading on the remaining units may be carefully increased to allow the upset unit to recover.
 - If upset affected multiple units a method of dealing with excess solids may be required.

Alkalinity Addition

- Alkalinity addition can be calculated using the following procedures:
 1. Determine the volatile acid and alkalinity concentrations (as CaCO_3)
 2. Using a target VA:ALK ratio of 0.1 and measured volatile acid concentration, calculate the desired alkalinity using the following equation:

$$\text{Alkalinity} \left(\frac{\text{mg}}{\text{L}} \right) = \frac{\text{Volatile Acids} \left(\frac{\text{mg}}{\text{L}} \right)}{0.1}$$

3. Subtract the measured alkalinity value from the alkalinity requirement calculated in step 2 to determine the alkalinity addition requirement.
4. Calculate the required chemical dose based on the equivalent weight ratio and purity of the alkali to be used.

$$\text{Chemical Addition (lb)} = \frac{\text{Alkali addition} \left(\frac{\text{mg}}{\text{L}} \right) \times \text{digester volume (gal)} \times 8.34 \left(\frac{\text{lb}}{\text{gal}} \right)}{106}$$

Alkalinity Addition (cont.)

- Dose the calculated amount of chemical over an extended period to avoid scaling on the heat exchanger or pipelines. Typically, alkalinity is added over a 3- or 4-day period. Mix well, and frequently monitor volatile acids, pH, and alkalinity. Avoid toxicity from the cations associated with the alkalis. Confirm that the vacuum-relief device is operable.
- Use caution if using ammonia due to toxicity issues.

Alkalinity Equivalent Weight Ratios		
<i>Chemical Name</i>	<i>Formula</i>	<i>Ratio</i>
Anhydrous ammonia	NH ₃	0.32
Aqua ammonia	NH ₄ OH	0.70
Anhydrous soda ash	Na ₂ CO ₃	1.06
Caustic soda	NaOH	0.80
Hydrated lime	Ca(OH) ₂	0.74

Control Strategies for Upsets

- For Foaming:
 - Reduce feed
 - Check VSLR and PS:WAS ratio
 - Reduce VSLR if too high and increase PS:WAS ratio if too low
 - Check mixing system and enable continuous mixing
 - Check scum/FOG feed and reduce quantity in feed
 - Blend feed substrates and feed continuously if possible
 - Check secondary process for filaments and foaming and implement control methods there
 - Clean digester gas system components if foam entered

Polling Question

- Which of the following is FALSE?
 - a) Mixing helps prevent digester contents from stratifying.
 - b) Digesters can become upset under variable feeding conditions.
 - c) Maintenance to remove struvite is straightforward.
 - d) An increase in VA:Alkalinity ratio is a sign of an upset condition.

5 Minute Break



WWOA would like to thank our generous sponsors and partners for their support of our mission to provide training and education opportunities for our members and others working in the water and wastewater profession.

2020 WWOA Virtual Operator Training Series

Accessible ~ Affordable ~ Informative

Anaerobic Digestion Virtual Operator Training ~ May 6, 2020

PRESENTING SPONSOR:



CONTRIBUTING SPONSORS:



Emerging Technologies/Innovations

Advanced Options Throughout Solids Treatment Train

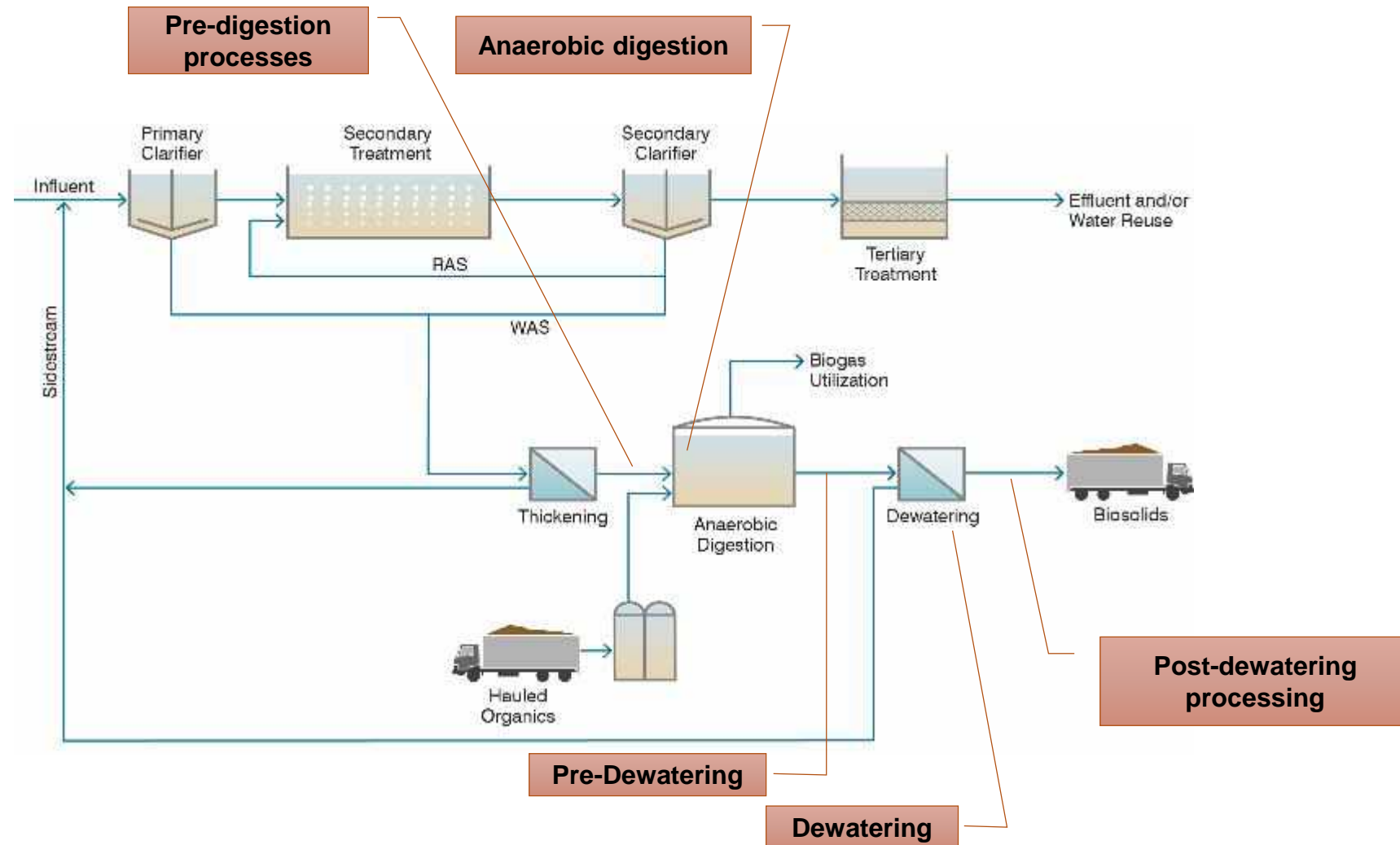

Pre-Digestion

Pre-digestion processes that make solids easier to digest/dewater

- Lyse cells to release contents
- Thermal hydrolysis processes (THP)
 - High temp; high pressure systems (pressure cooker): Cambi, Kruger/Veolia BioThelys, Kruger/Veolia Exelys, Haarslev, Eliquo, and others
 - 285 to 355 degrees F; 90 to 220 psi
 - Some batch; some continuous
 - Class A possible if all feed processed through THP
 - Lower temp thermo-chemical systems: PONDUS
- Sludge disintegration systems – mixed history
 - Ultrasound, Microsludge, Crown, OpenCEL

THP most widely used in Europe, but gaining ground in US

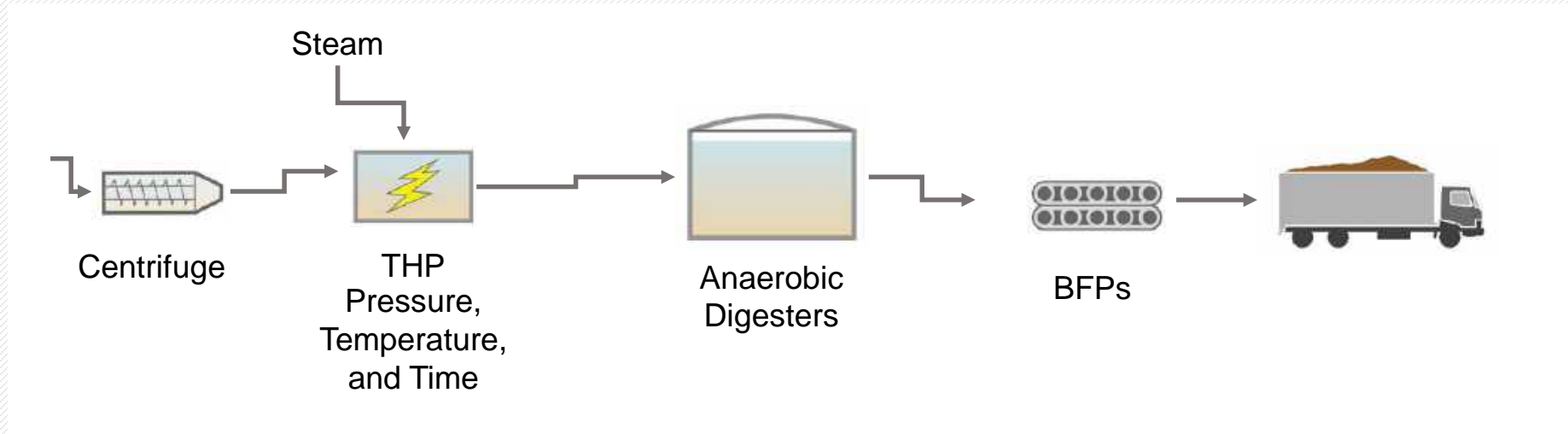

Key Design Parameters:

- Pre-dewatering to 15-25% solids
- Hydrolysis in THP; feed solids to digesters 8-12% (reduced viscosity)
- Digester loading limited by ammonia toxicity
- VSR ~ 60% to 65%
- Post-dewatering to 30%+ solids on BFP
- Other configurations: Between digesters, WAS only, post-digestion

How does THP work?

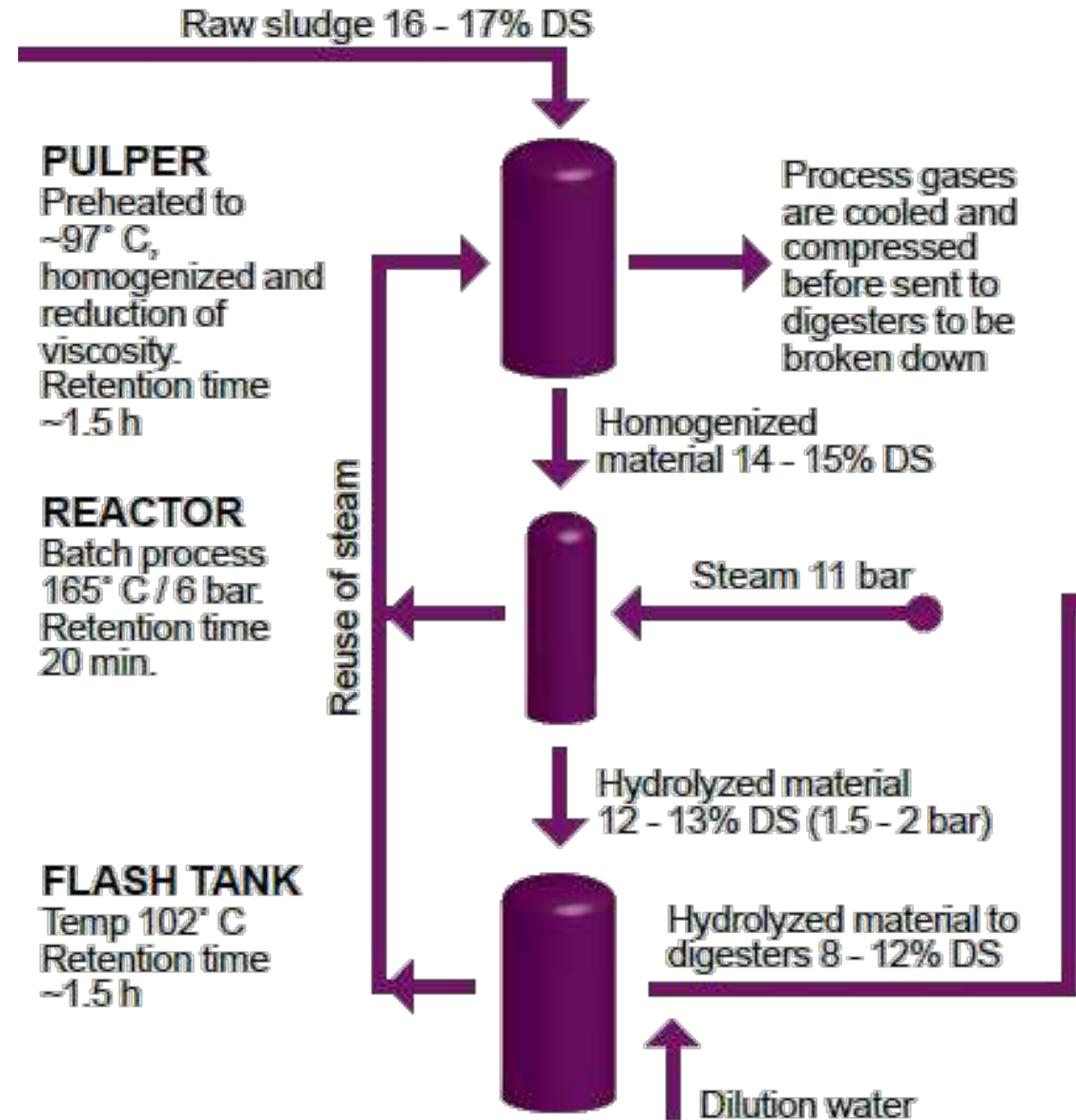

Cambi THP

The History of Cambi

- Cambi – Developed in 1990s
- 50+ worldwide installations
- ~15 additional installations in planning, design, or construction worldwide
- DC Water was 1st US installation and Medina 2nd (both operating now)
 - SFPUC, HRSD, Trinity River Authority, Pontiac soon

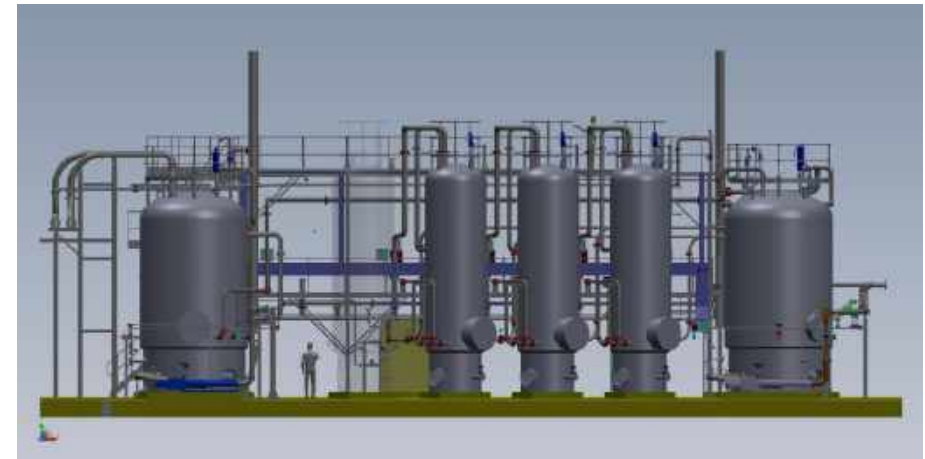

Veolia's Exelys thermal hydrolysis system is a continuous process

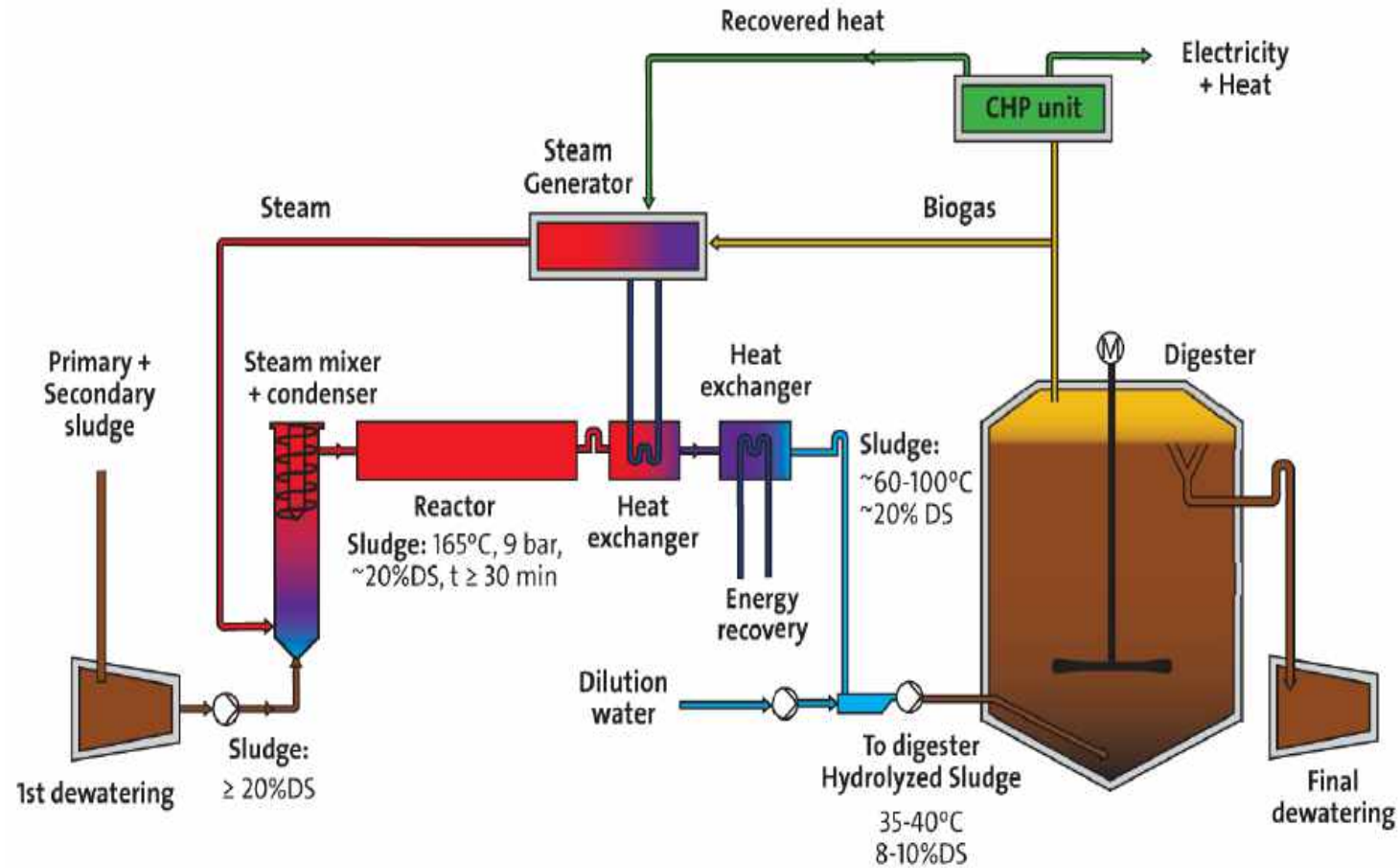

THP: The Good and the Bad



ADVANTAGES	DISADVANTAGES
<ul style="list-style-type: none">• Solids Reduction• Dewaterability• Digestion tank volume• No pathogen regrowth• Class A (if all feed processed)	<ul style="list-style-type: none">• Capital Cost• Sidestream• U.S. Installations• Odor control• Tea-colored recycle stream• Steam and pressure• Energy Usage• Pre-dewatering• Complexity• Cooling steps

Sludge Pretreatment – PONDUS Thermo-Chemical Hydrolysis Process



A Recap of the Benefits of PONDUS Hydrolysis (TCHP)

DESCRIPTION	RANGE
Increase of biogas production	25 to 35%
Reduction of polymer consumption at dewatering	Up to 20%
Increase of dry cake solids at dewatering	Up to 5%
Caustic soda consumption	1,500 to 2,000 ppm
Energy consumption	0.9 to 1 kWh/m ³ Sludge
Reduction of viscosity in hydrolyzed sludge	Up to 80%

Ref: CNP Pondus

PONDUS process operates at lower temperatures and targets secondary sludge

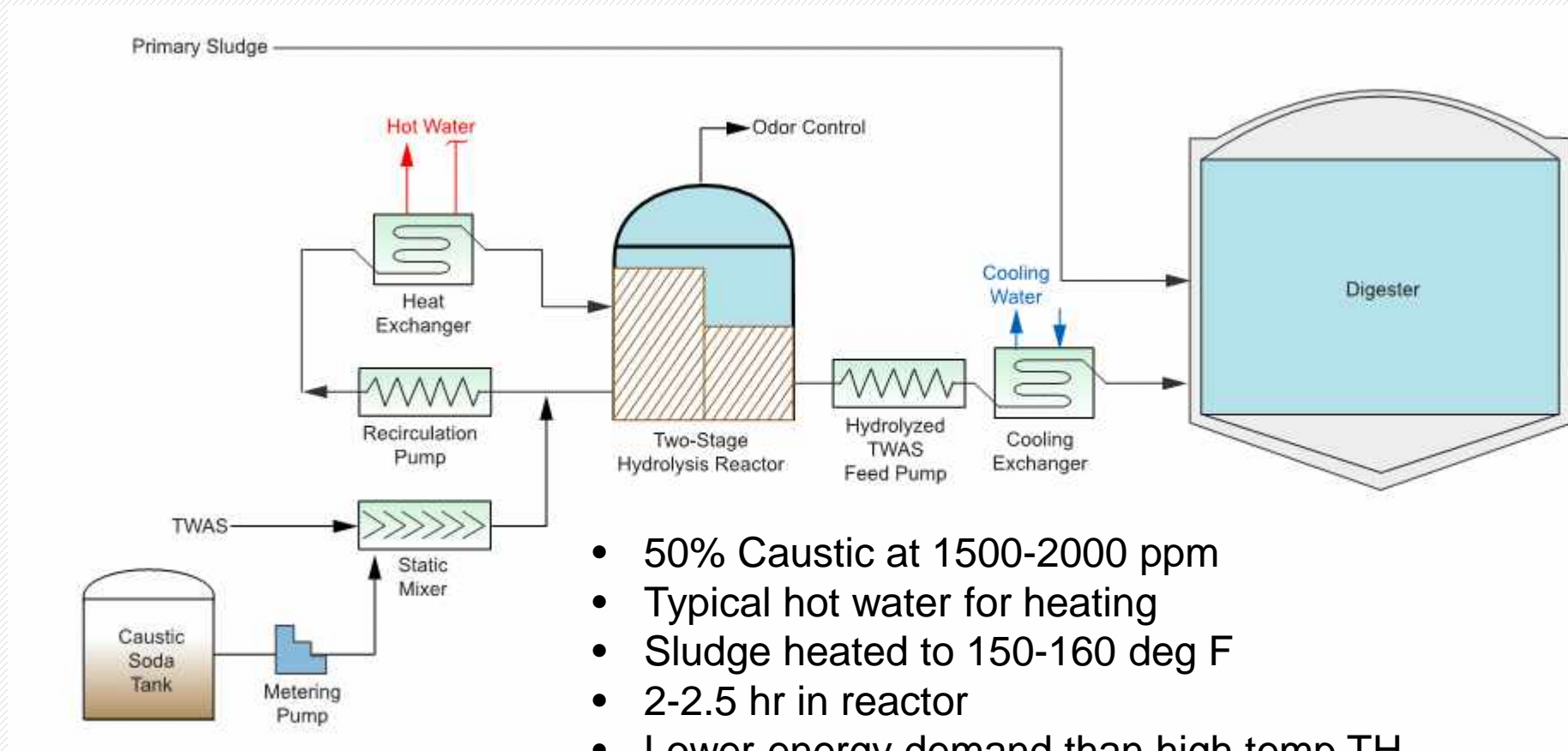

- 50% Caustic at 1500-2000 ppm
- Typical hot water for heating
- Sludge heated to 150-160 deg F
- 2-2.5 hr in reactor
- Lower energy demand than high temp TH
- Not Class A without further treatment or different configuration/size

Advanced Digestion Processes

Typical thickened feed to tanks in parallel

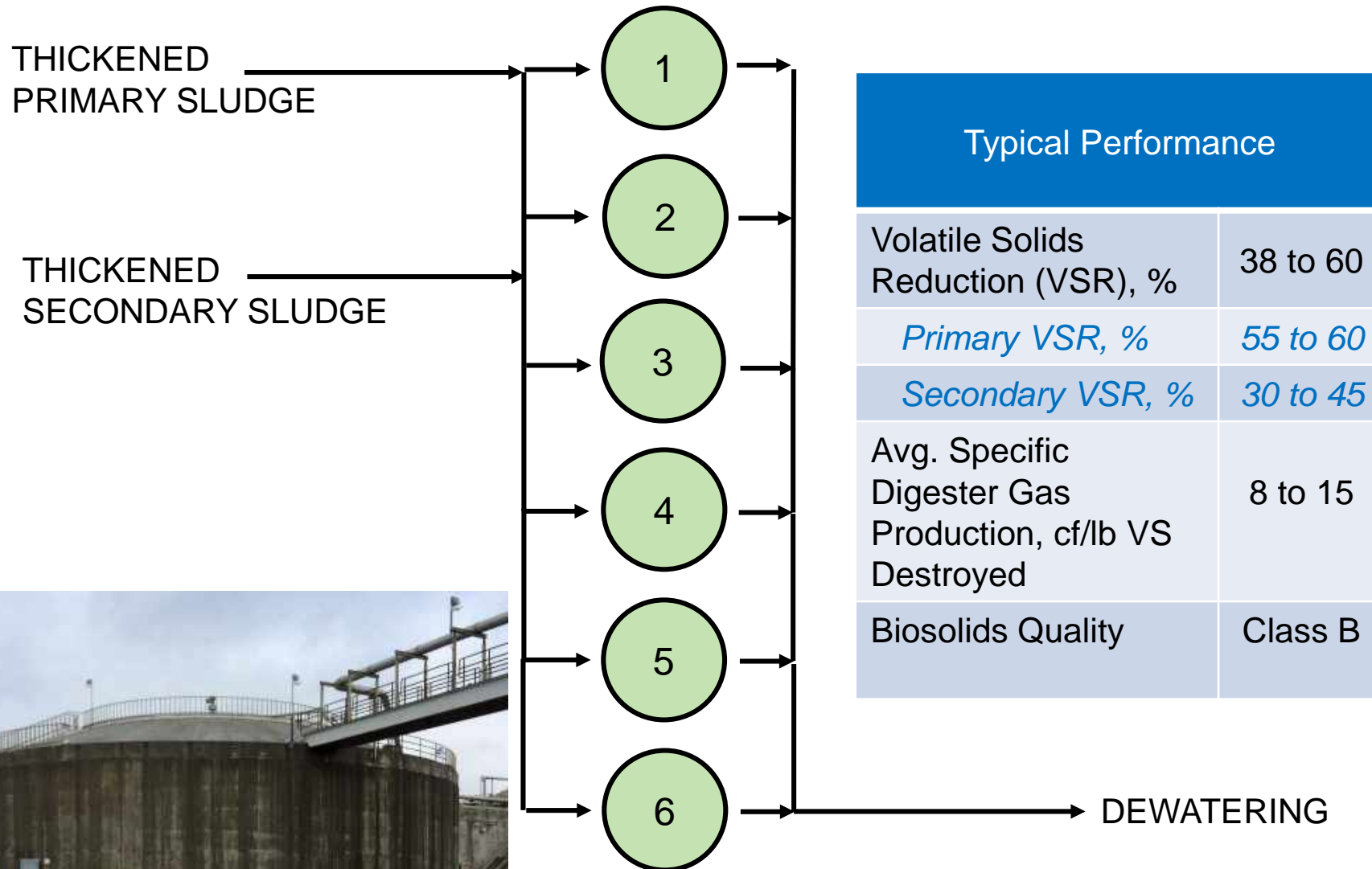

Digestion in series reduces short-circuiting and increases volatile solids destruction

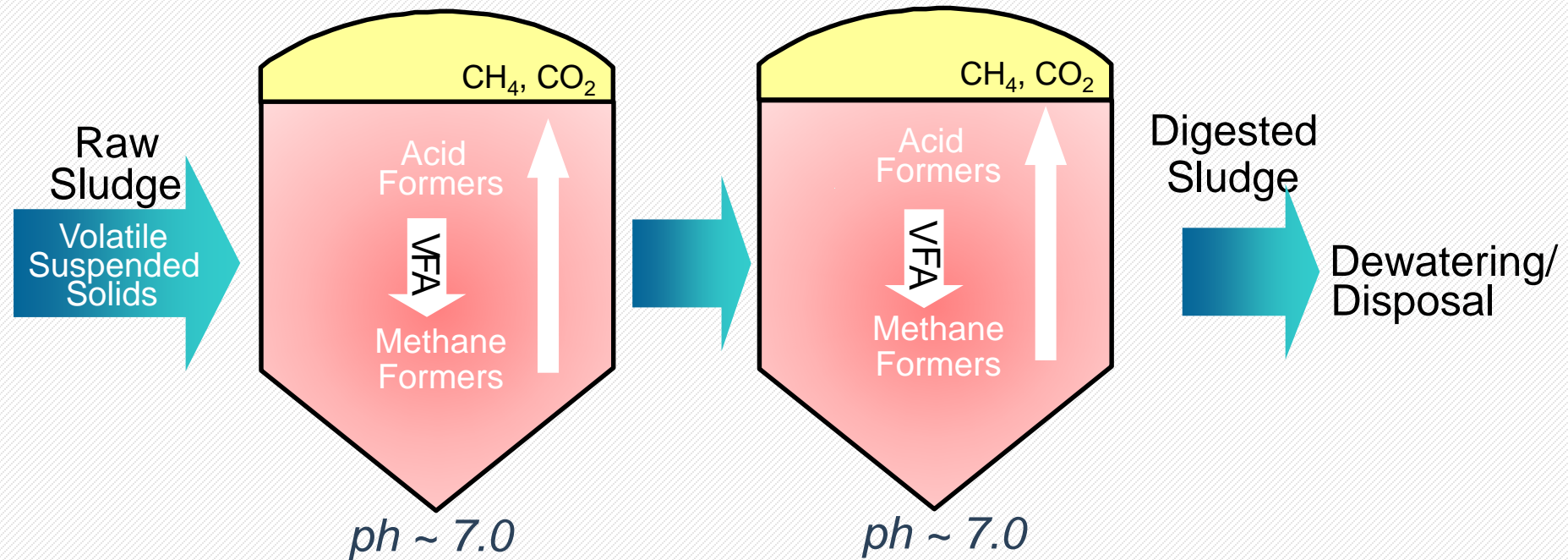

- *Thermophilic temperatures ~ 122-133°F (potential for Class A)*
- *VSR improvement from ~50% to >60% at Annacis Island, Lions Gate (Vancouver) and Mason Farm (NC)*
- *Operational changes, large heating systems, odors, susceptibility to temperature*

Another potential way to improve process performance is through phasing

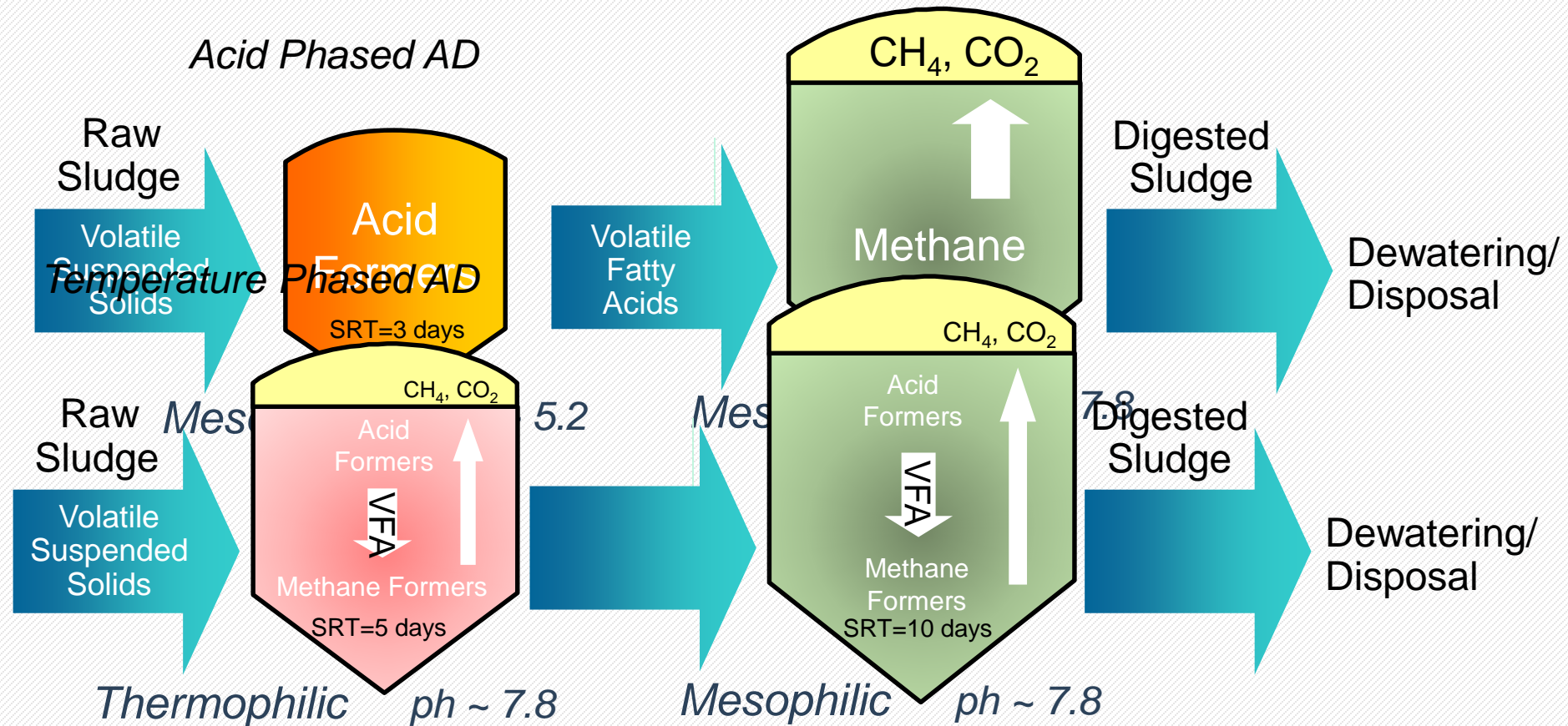

The good...

- Potential benefits of APAD
 - Increased process stability
 - Same or more VSR with shorter SRTs
 - Easier to implement FOG/FW digestion
 - Better methane phase gas quality
- Potential benefits of TPAD
 - Same or more VSR with shorter SRTs
 - Fewer odors than thermophilic only
 - Class A possible with batch tanks or monitoring/approval

The not so good...

- Potential drawbacks of APAD
 - Odorous acid phase sludge and low BTU gas
 - Best operations opposite of most conventional training
 - Struvite/vivianite formation
- Potential drawbacks of TPAD
 - Larger heating system required and susceptibility to heating system failure
 - Moisture in gas
 - Struvite/vivianite formation

Advanced digestion processes operate with higher loading rates/shorter SRTs

Configuration	SRT per Tank (days)	Combined SRT (days)	Temperature	Max VS Loading Rate (lb/cfd)	Biosolids Quality
Conventional	20	20	M	0.15	Class B
Acid Phase	3/12	15	M/M	2.5	Class B
Thermophilic	15+	15+	T	0.3	Class A
Staged Thermophilic	17/2	19	T	0.3	Class A
TPAD	5/10	15	T/M	0.3	Class A
Multi-Phase	3/12/2	17	M/T/M	2.5	Class A

High solids digestion (HSD) intensifies the process and reduces required tank volume

Omnivore Increases Digestion Capacity for Greater Energy Production or Consolidating Capital

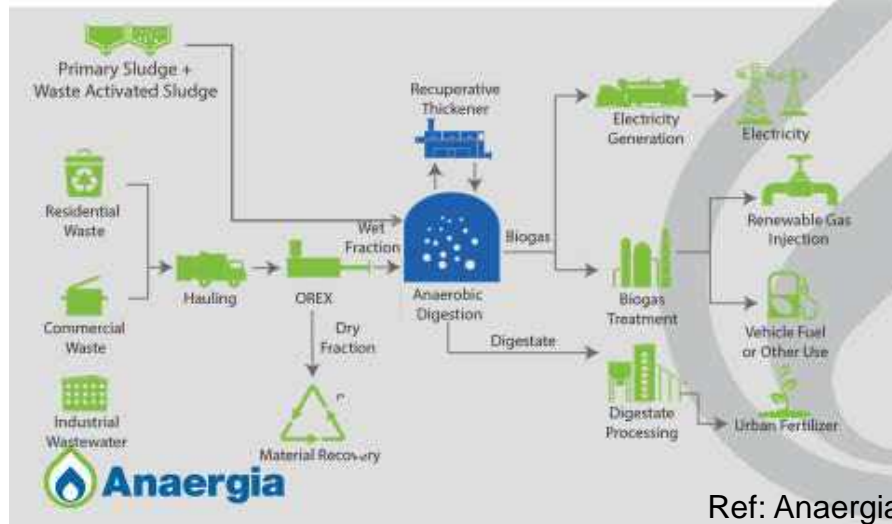

GE Power & Water
Water & Process Technologies

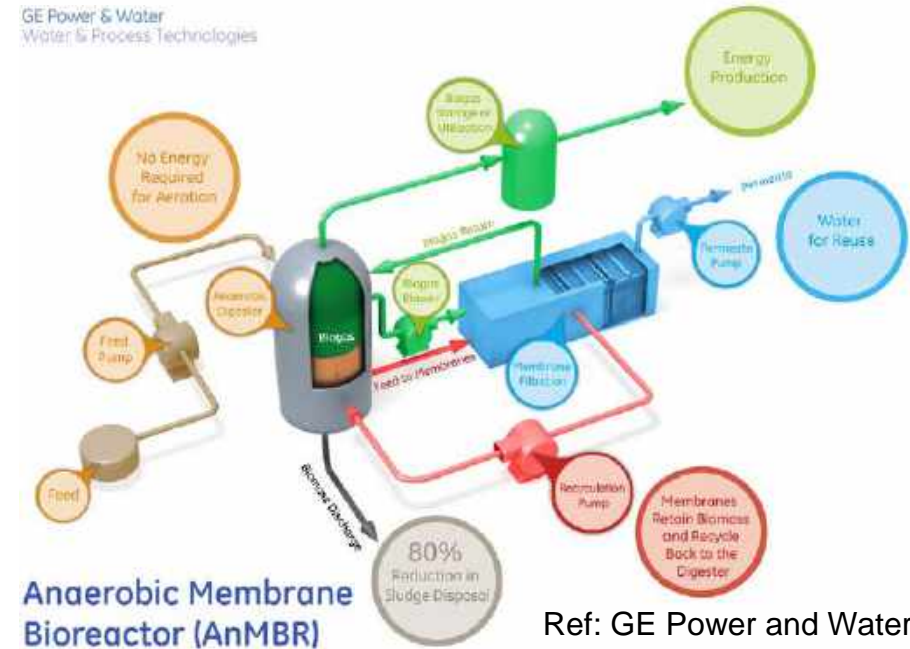

Organics diversion, anyone?

Anaergia Omnivore HSD: Increasing digestion capacity for co-digestion and capital offset

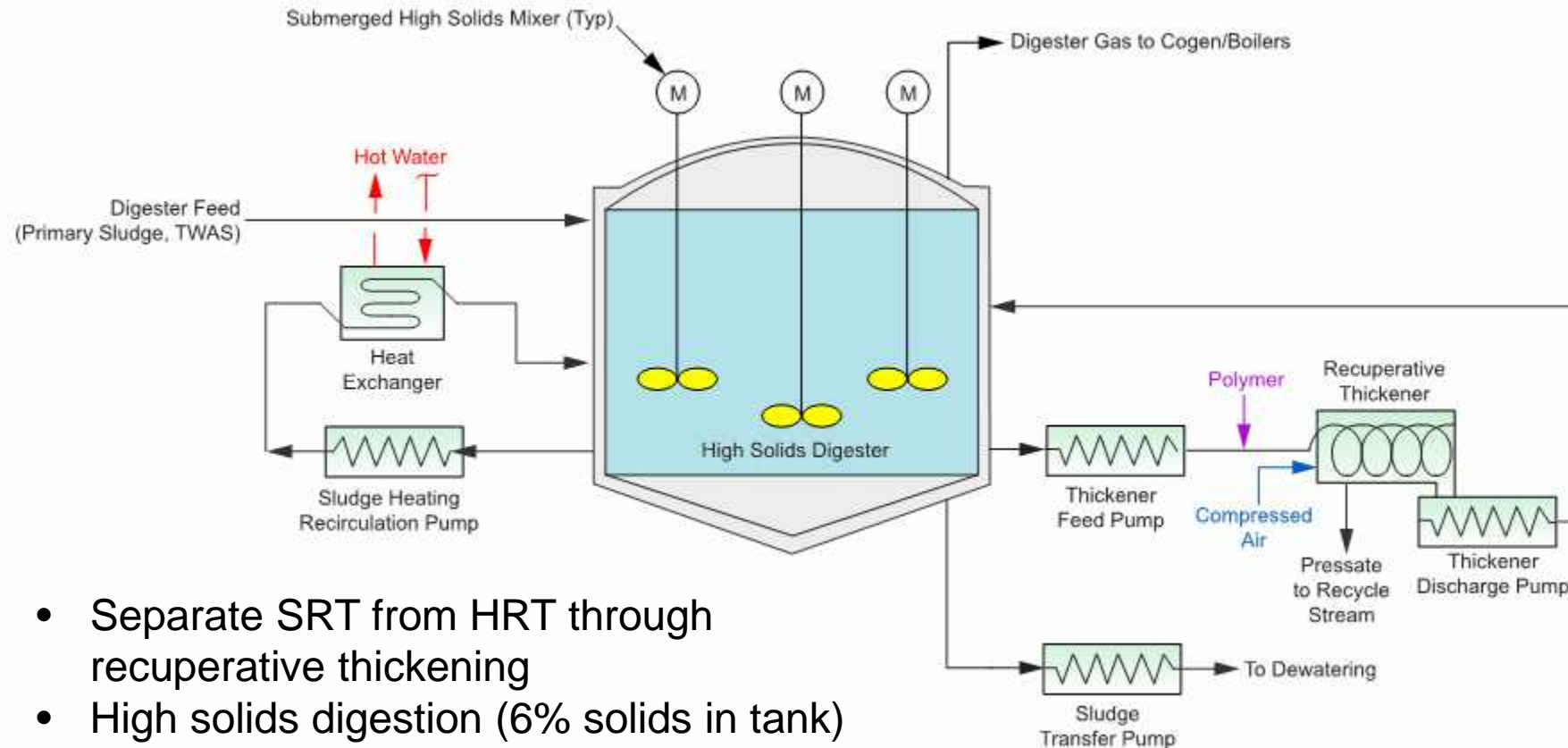

- Separate SRT from HRT through recuperative thickening
- High solids digestion (6% solids in tank)
- High solids mixers

Recuperative thickening and high solids mixing are essential to HSD

Omnivore™ = Mixers + Thickening

1. Omnivore retrofit:

- High Solids Mixers
- Recuperative Thickening
- Service Boxes: isolated service boxes for safe in-situ mixer adjustment



Ref: Anaergia

Recuperative thickening and high solids mixing are essential to HSD

Screw Thickener Concentrates Biomass



SST 225 Screw Thickener



Feed Sludge and Filtrate



Thickened Sludge

- Feed digested sludge 6% TS
- Return thickened sludge 12%TS
- Filtrate 200 mg/L TSS
- Solids recovery 95%
- Polymer dose 2.5 kg/ton TS {Polymer reactivated reducing downstream dewatering demand}
- Thickener power <10 HP including pumps

Omnivore at Victor Valley handed over in 2014

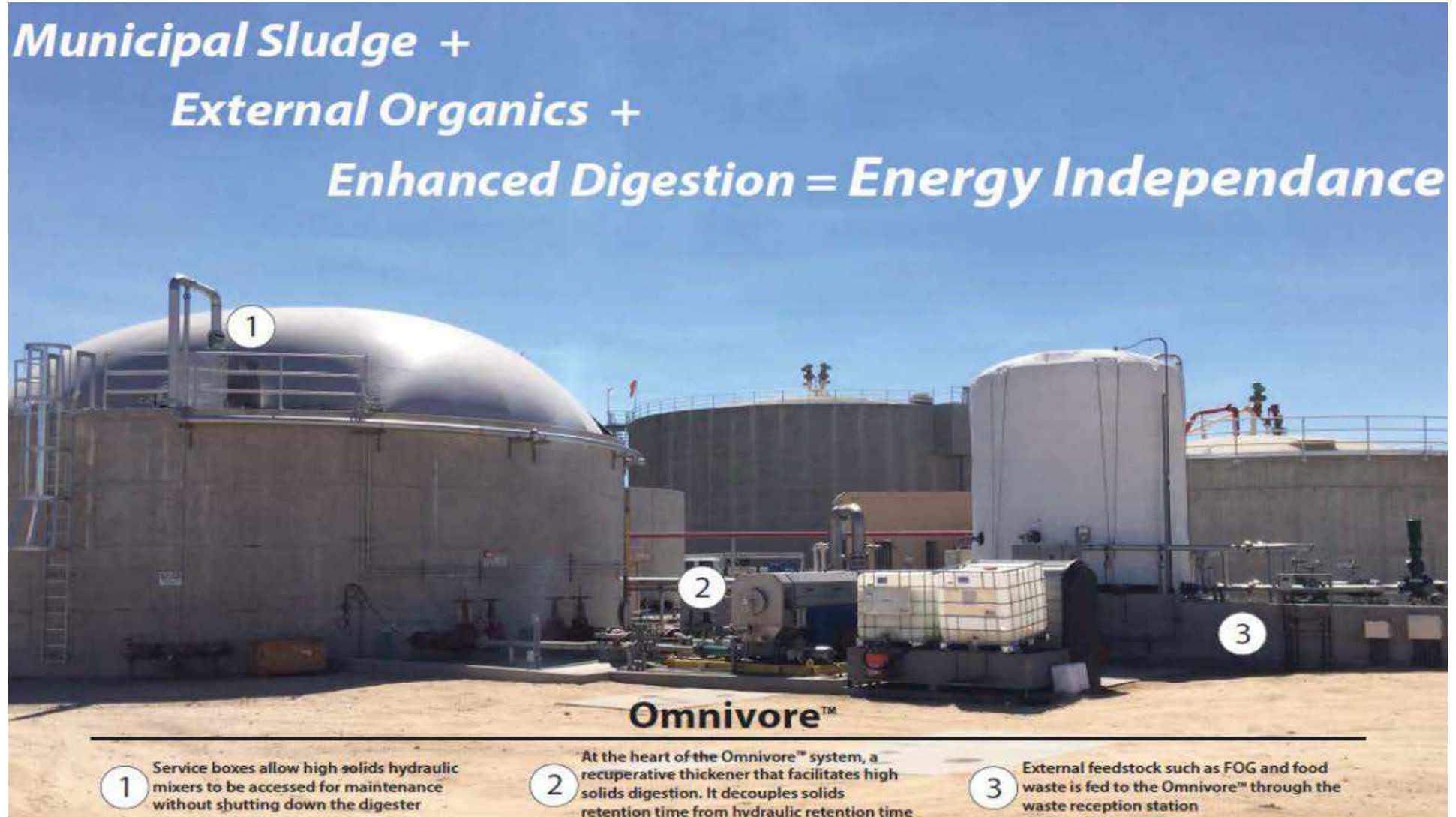

Ref: Anaergia

Operating experience at Victor Valley included side-by-side digestion

- Two existing large digesters – 1.2 MG/tank
 - 60/40 PS/TWAS feed and 1.8% solids digester content
 - Organic loading rate of 0.08 lb VS/cf-day
 - Gas production rate at 14 cf/lb VS destroyed
- Omnivore – 300,000 gal
 - Started with 60/40 sludge feed and 1.8% solids content in digester
 - Gradually increased solids concentration and OLR to 0.25 lb VS/cf-day
 - Added external feedstock and OLR rose to 0.3 lb VS/cf-day
 - At lower digestion volume and HRT, gas production similar to standard digesters
 - **VFA:Alk <0.1**

Operational Experience – Victor Valley, CA

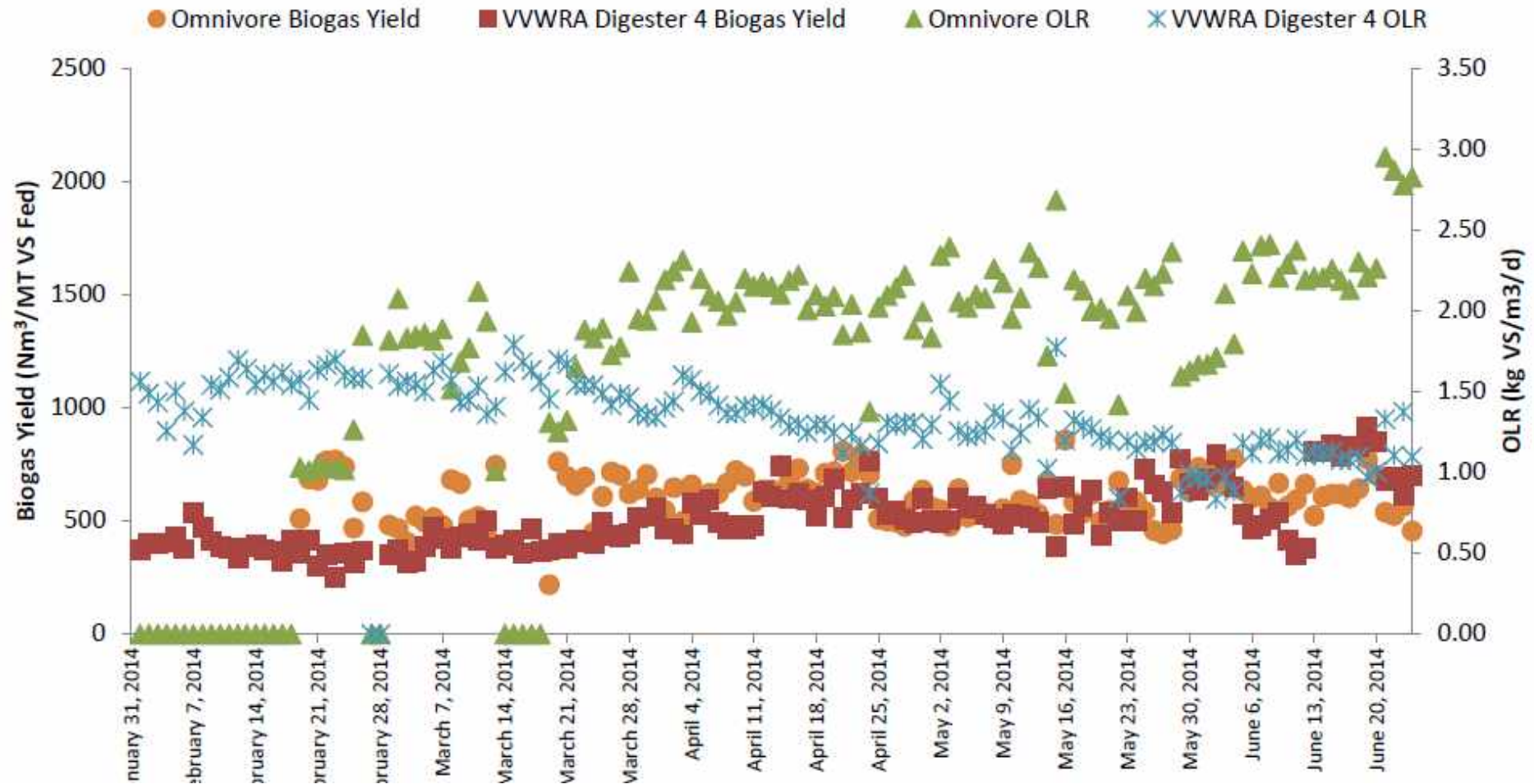

Ref: Anaergia

Operational Experience – Victor Valley, CA

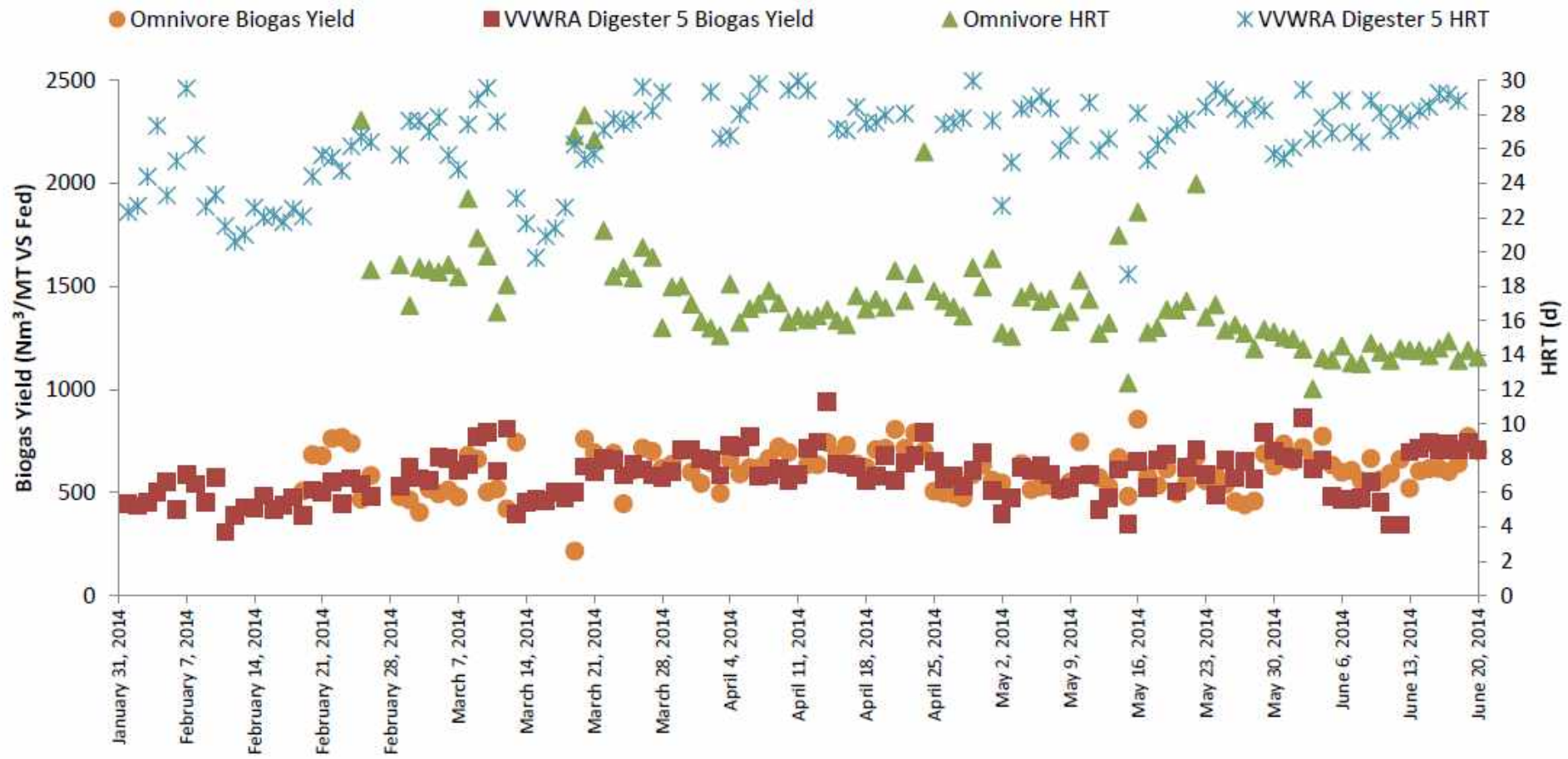

Ref: Anaergia

Co-digestion 101: Waste-to-Green Energy

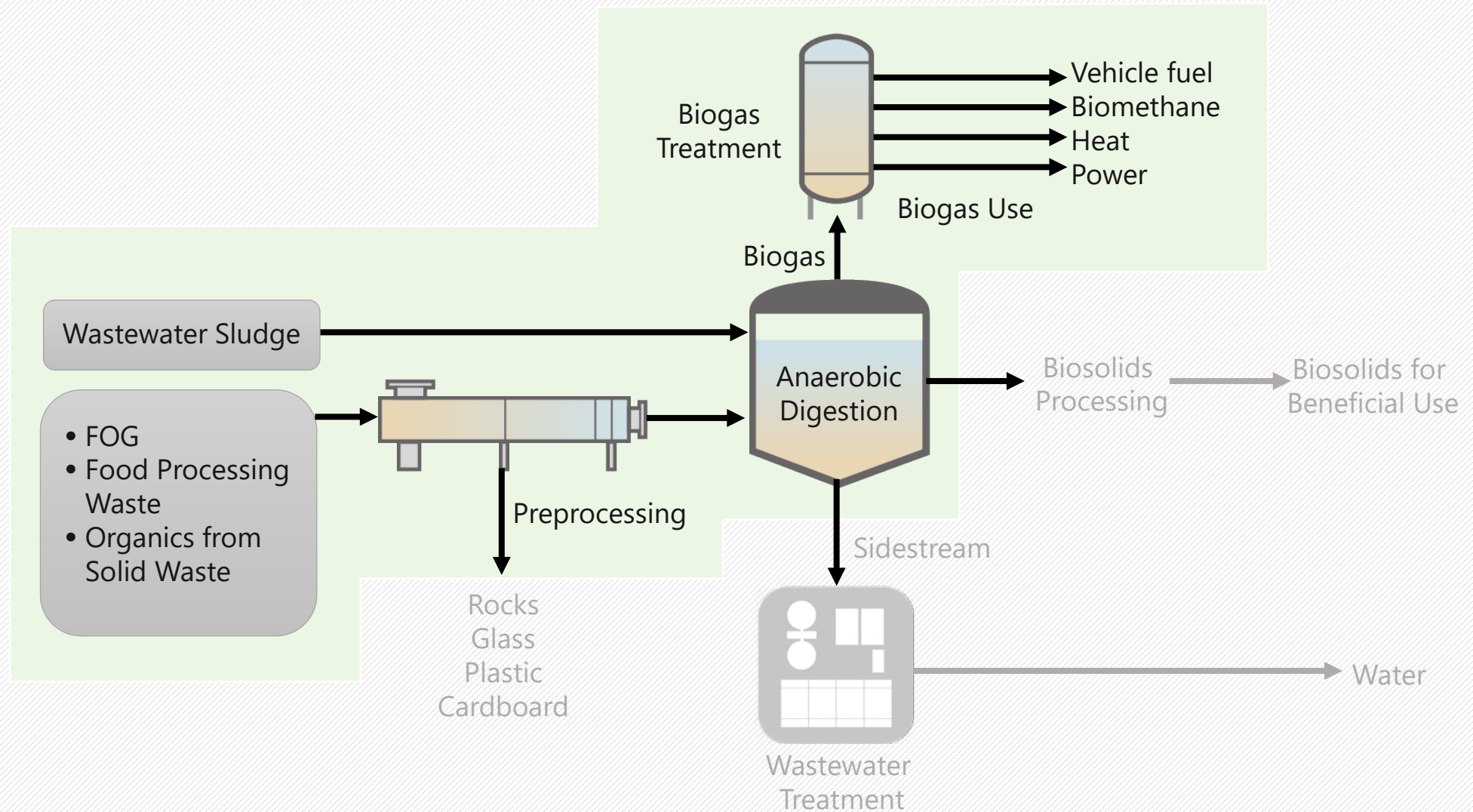

Post-Digestion

Post-digestion processes to recover/remove phosphorous and reduce struvite

- Targeted formation of struvite by creating conditions for precipitation
 - Addition of magnesium chloride
 - Air stripping for pH elevation
- Removes struvite before it forms downstream of digestion
- Improves dewaterability through phosphorous removal
- AirPrex (CNP) and NuReSys offer systems for digestate (pre-dewatering)

Ostara WASSTRIP/Pearl targets both sides to reduce struvite within digesters

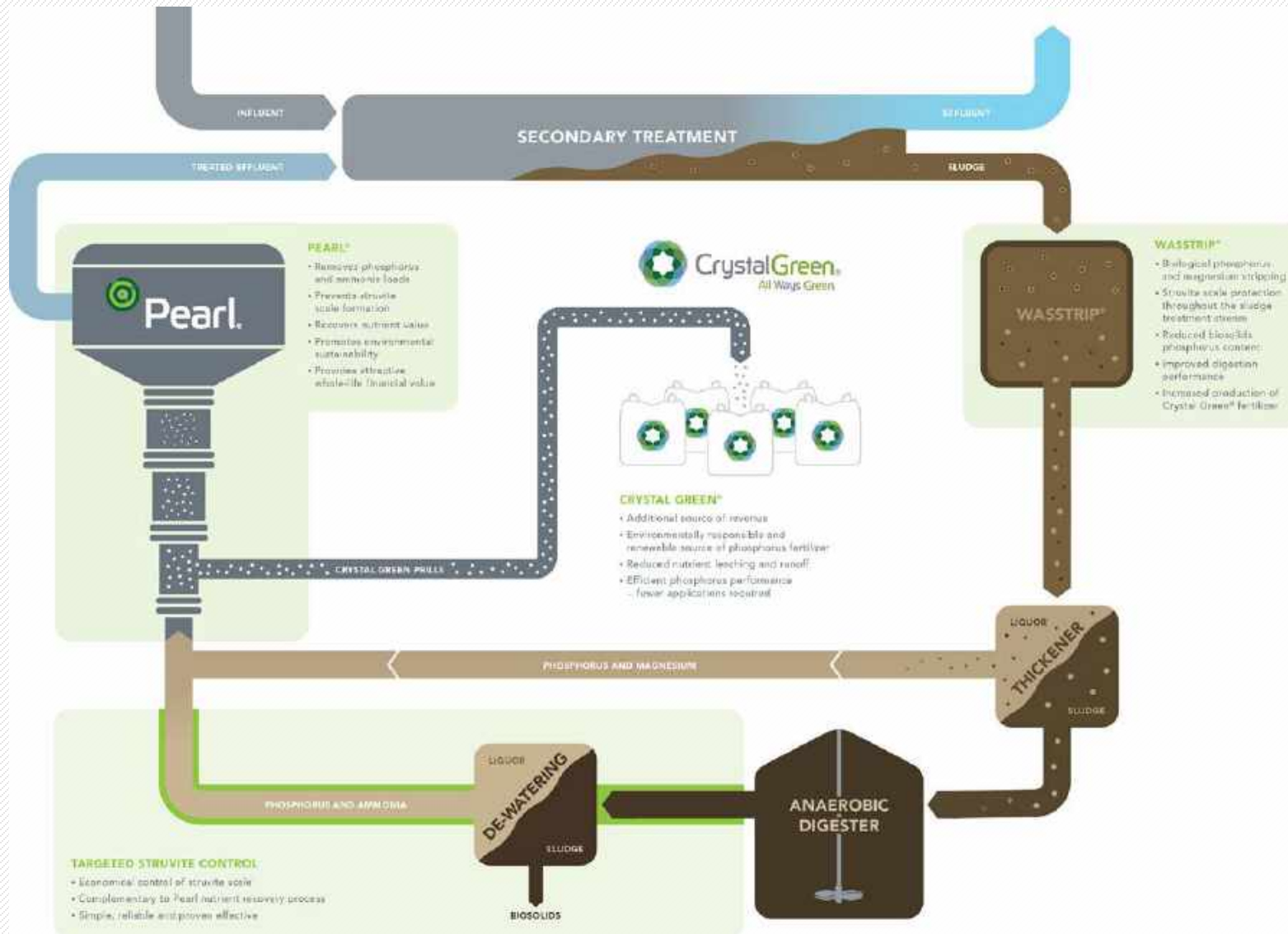

AirPrex and NuReSys systems target digested sludge before dewatering

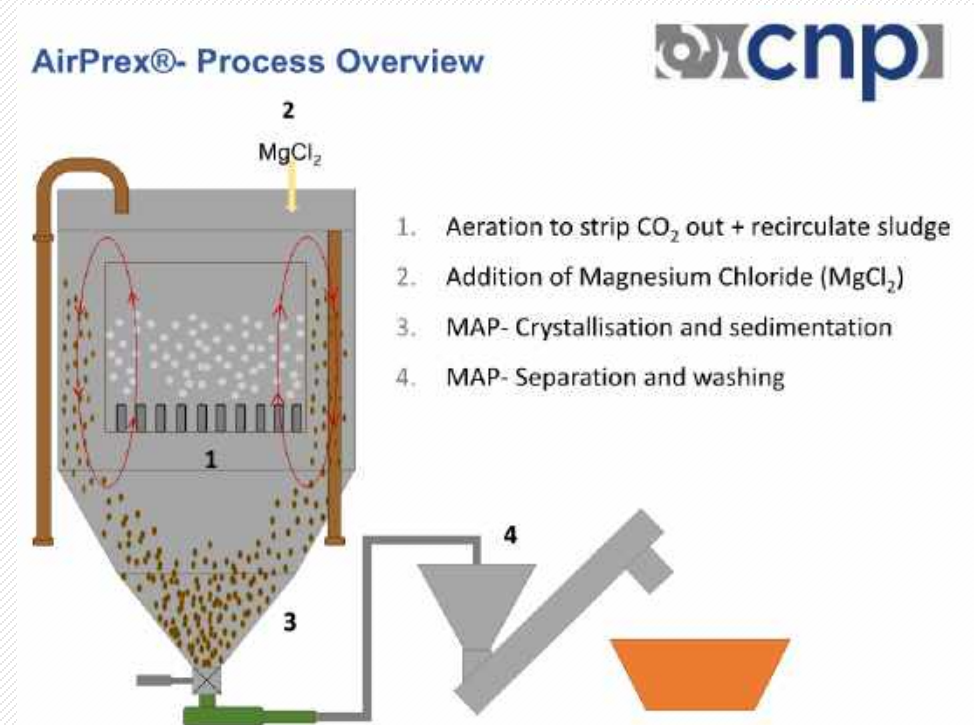
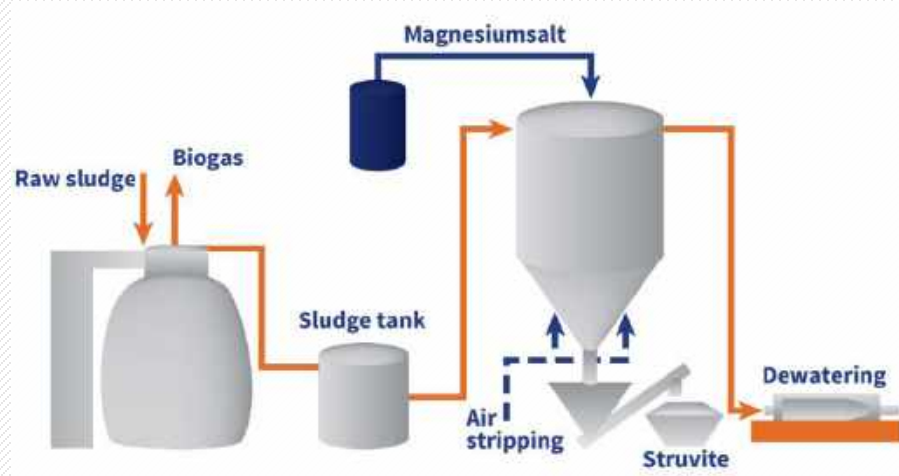

Biosolids end use options to reduce volume and/or produce marketable products

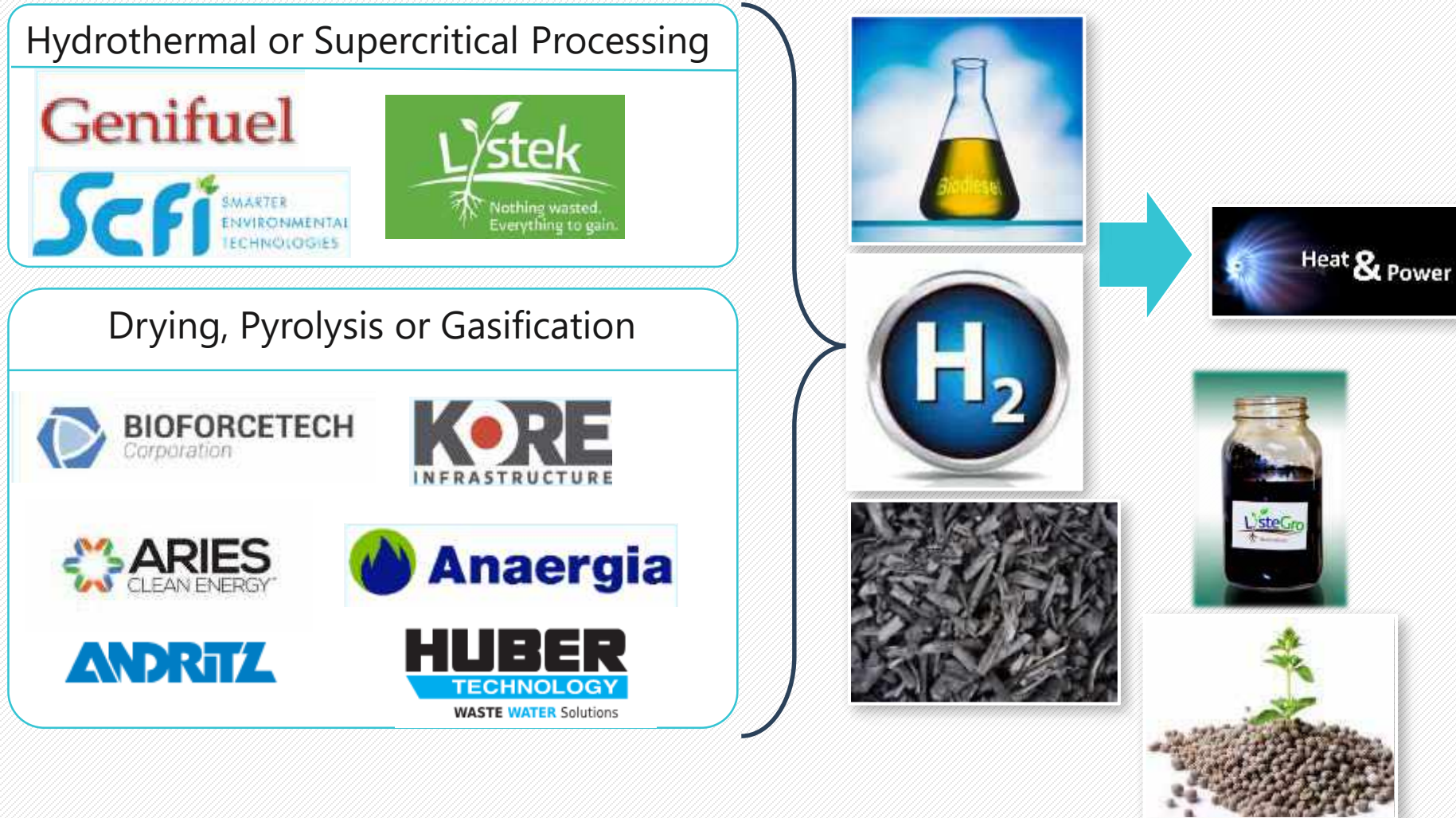

Lystek Thermo-Chemical Hydrolysis (Post-Digestion)

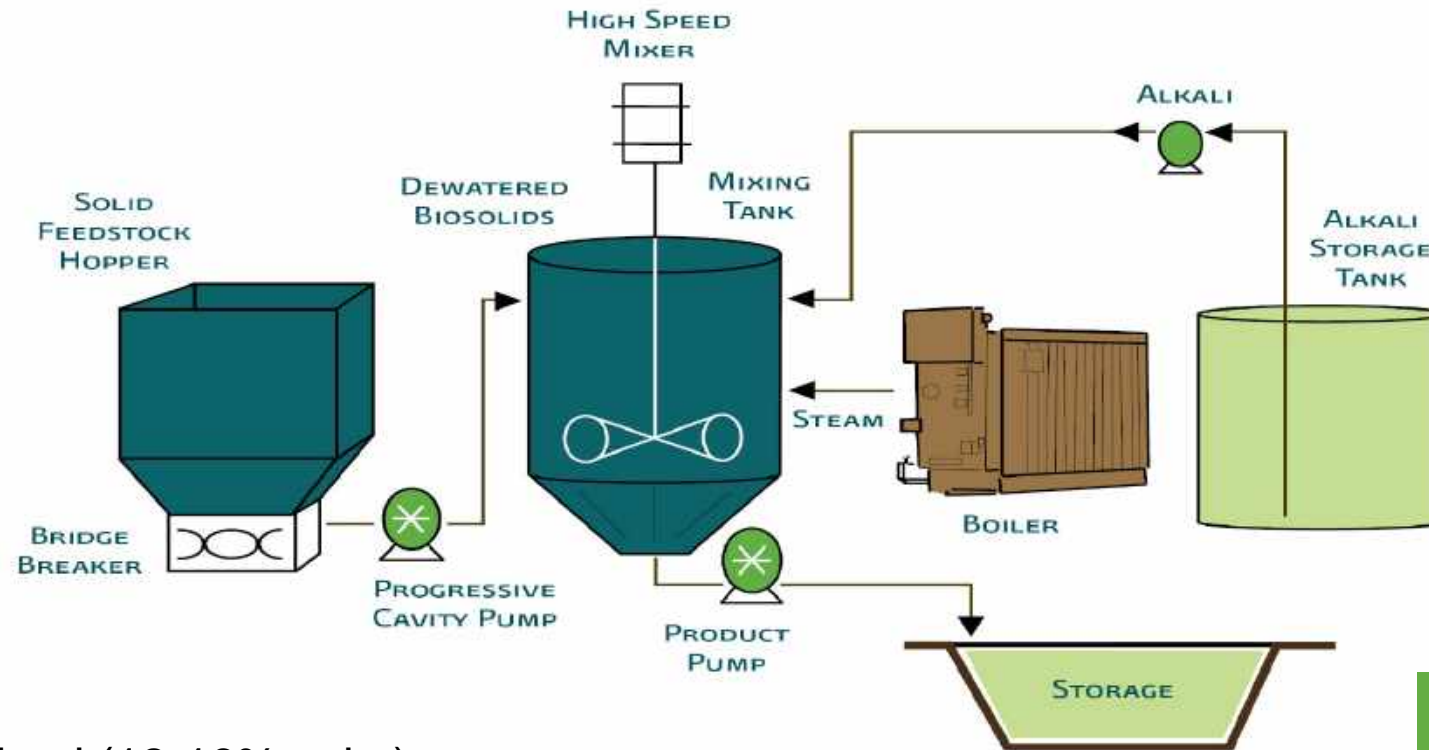

- Dewatered Cake Feed (12-16% cake)
- Low Pressure Steam + Alkaline Chemical to Increase Temp and pH
- Mixing and Lysis in Reactor
- Class A EQ Liquid Fertilizer End Product
- US Installations: Fairfield Suisun San District, CA; St. Cloud, MN





Biogas

Historical biogas use

- Digester heating
- Cogeneration
- Flare remainder of biogas

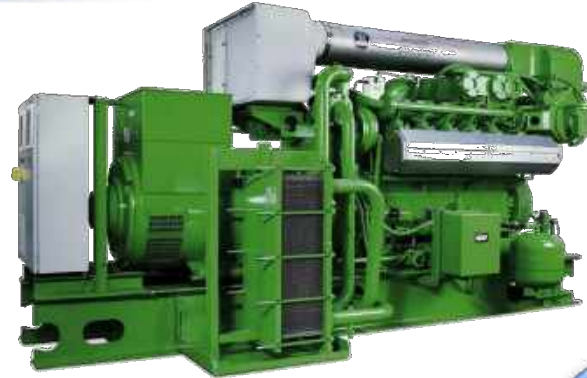

Renewable credits are driving consideration of other beneficial options

- Vehicle fuel



- Pipeline injection



EPA's Renewable fuel standard program can turn these beneficial use options into revenue streams

- Energy Policy Act (2005), updated Energy Independence and Security Act (2007)
- Qualifying fuels: biomass-diesel, **cellulosic**, advanced biofuel, renewable biofuel
- Renewable identification numbers (RINs)
- Obligated parties: refiners or importers of gas/diesel

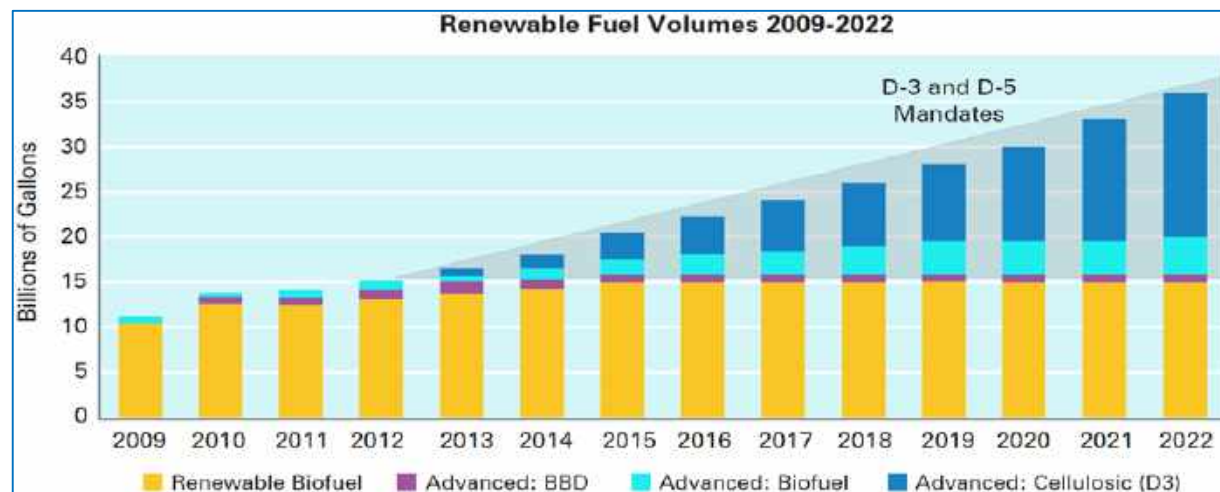

Biogas end use dictates treatment level

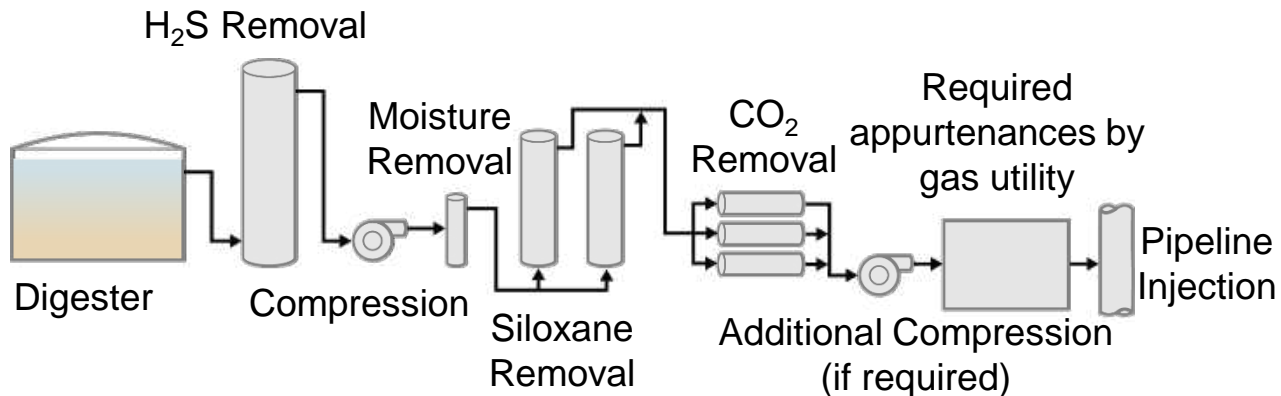
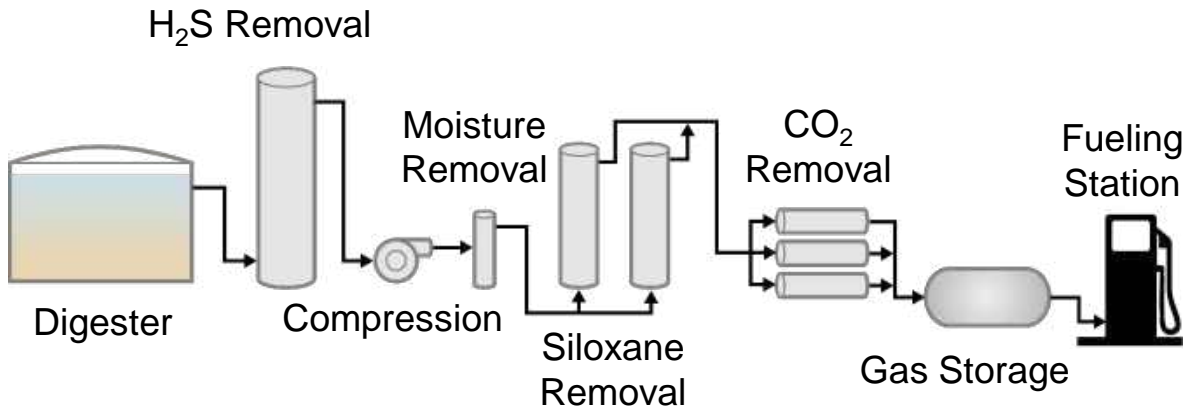
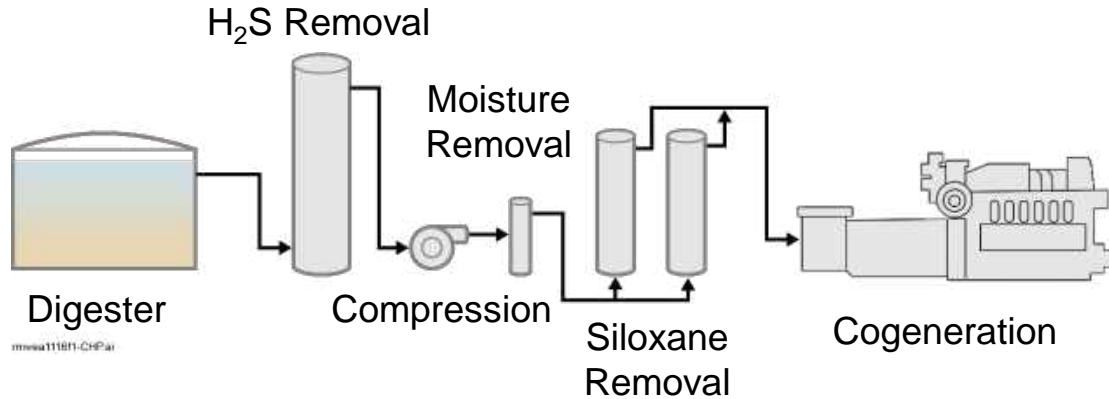

Further innovations are on the horizon

- Biosolids drying
- Bioplastics
- Denitrification carbon source



Polling Question

- Which of the following is FALSE?
 - a) High Solids Digestion relies on a separation of SRT from HRT.
 - b) Thermal hydrolysis processes (THP) all operate in batch mode.
 - c) Thermo-chemical hydrolysis processes use less energy than THP processes to improve digestion and dewatering.
 - d) Phosphorous removal before digestion can reduce struvite formation in the digesters.

The End – Thank you!

Feel free to contact us:

Becky Luna
bluna@carollo.com

Brian Graham
bgraham@carollo.com

Rashi Gupta
rgupta@carollo.com



WWOA would like to thank our generous sponsors and partners for their support of our mission to provide training and education opportunities for our members and others working in the water and wastewater profession.

2020 WWOA Virtual Operator Training Series

Accessible ~ Affordable ~ Informative

Anaerobic Digestion Virtual Operator Training ~ May 6, 2020

PRESENTING SPONSOR:



CONTRIBUTING SPONSORS:





WISCONSIN WASTEWATER
OPERATORS' ASSOCIATION