



Biological Nutrient Removal Leads to Energy Savings

Greg Droessler, P.E.

Diane Thoune, P.E.

October 8, 2015



Today's Agenda

1. Introduction
2. Aeration design and BNR modeling
3. Process design
4. System calibration and results



LCPWD NCT Plant

Facility Design

- ▶ 6.0 MGD average daily flow
- ▶ 18.0 MGD peak daily flow

Current Operation

- ▶ 3.1 MGD average daily flow
- ▶ 10.2 MGD peak daily flow

Original Scope

- ▶ Design of a new blower to optimize aeration
- ▶ Look at the feasibility of BNR



LCPWD NCT Plant



Blower Addition / Biological Nutrient Removal Analysis

Aeration Analysis

Existing centrifugal blowers

- ▶ Constant speed
- ▶ 6,500 cfm capacity
- ▶ 7.3 mg/L average DO
- ▶ Average monthly electrical cost = \$21,000

New turbo blower with variable speed drive

Calculation of optimum supply air

- ▶ Based on BNR and conventional activated sludge options
- ▶ Sampling performed at plant
- ▶ Results entered into BioWin model



Aeration System Modeling

Model input parameters

- ▶ Flow
- ▶ BOD
- ▶ TSS
- ▶ Nitrogen
- ▶ Phosphorus
- ▶ pH
- ▶ Tank Dimensions
- ▶ Average DO



Aeration System Modeling

Model predicted

- ▶ Actual oxygen demand
- ▶ System air demand
- ▶ BOD & NH₄-N removal
- ▶ Sludge production



Biological Nutrient Removal Analysis

Developed and calibrated a BioWIN model

Extra plant sampling required

- ▶ VSS
- ▶ COD
- ▶ TKN
- ▶ Alkalinity

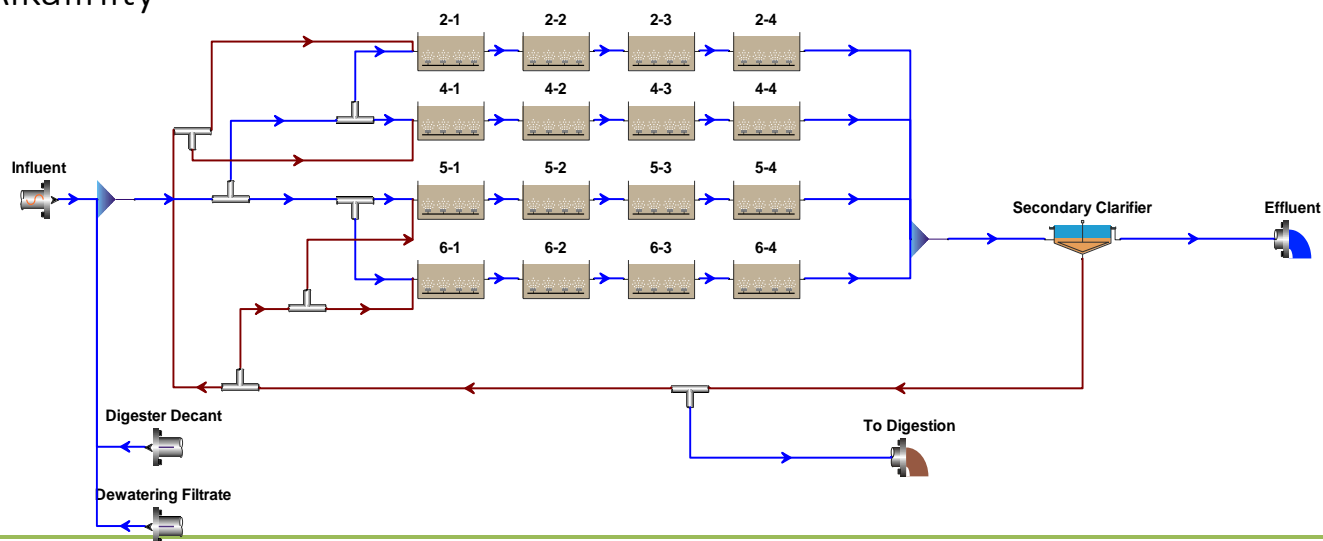

Biological Nutrient Removal Analysis

Calibrated model

Evaluated various types of BNR systems

- ▶ AO
- ▶ MLE
- ▶ Bardenpho
- ▶ UCT
- ▶ A2O
- ▶ 3 vs 6 aeration tanks

Model predicted various parameters

- ▶ Nitrogen and phosphorus removal
- ▶ Air requirement
- ▶ Effluent BOD
- ▶ Solids retention time

Aeration Basin 2 MLSS

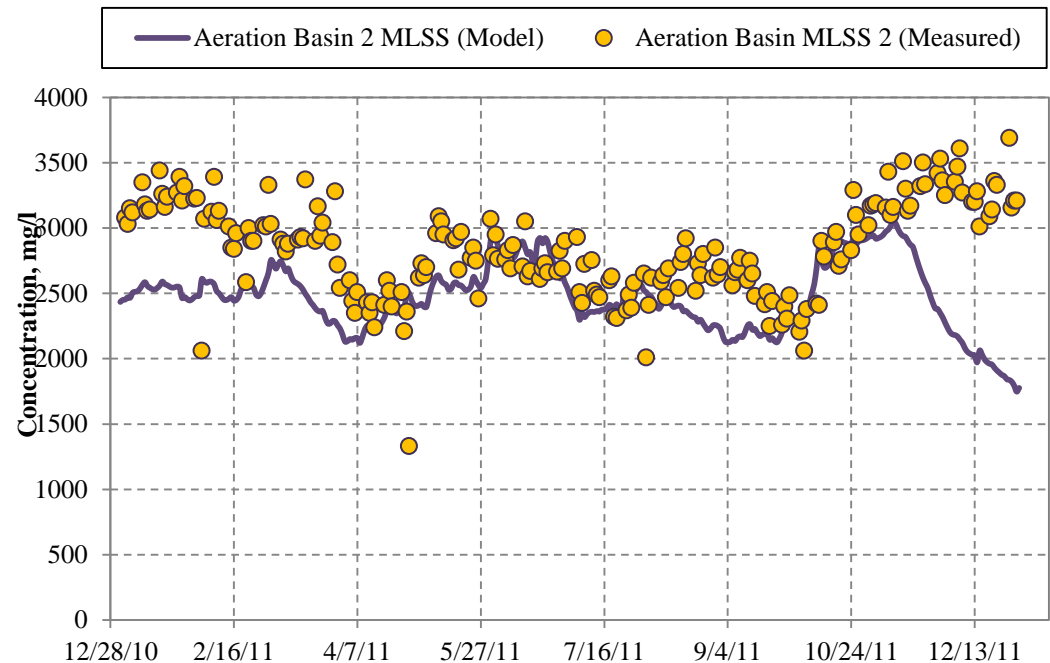

BNR System Schematics

A²O

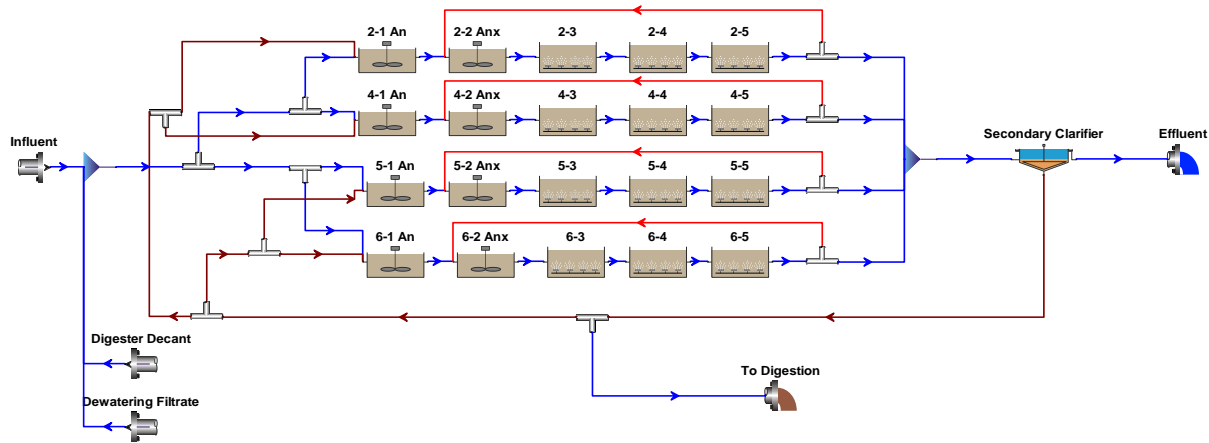

MLE

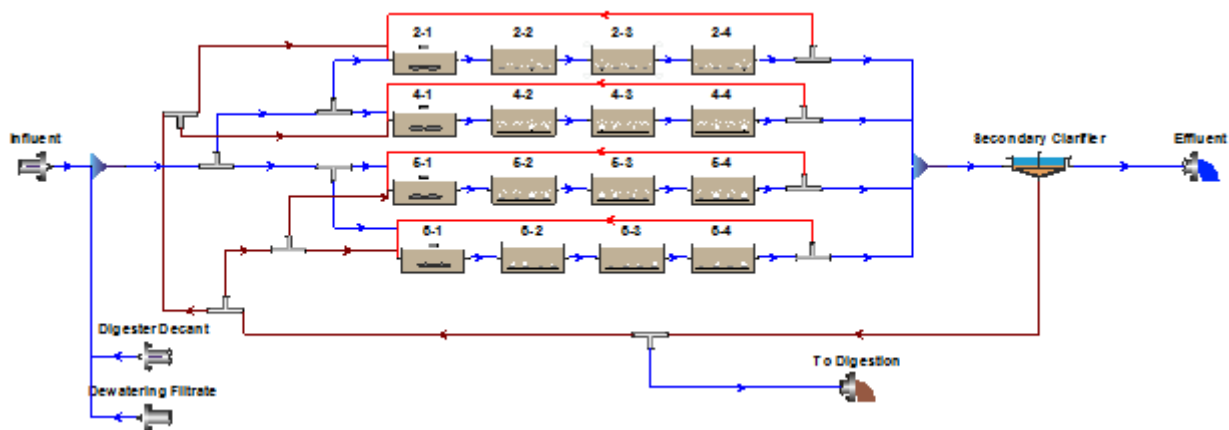

Predicted Nutrient Removals

Alternative	Influent		Effluent		% Removal, TN	% Removal, TP
	TN, mg/l	TP, mg/l	TN, mg/l	TP, mg/l		
Alternative 1 – Existing ASP with DO Control	28	4.5	20	2.5	29%	45%
Alternative 2 – A/O Process	28	4.5	11	0.4	60%	90%
Alternative 3 – MLE Process	28	4.5	4	2.5	85%	46%
Alternative 4 – Bardenpho Process	28	4.5	3	2.4	88%	48%
Alternative 5 – A ² /O Process	28	4.5	6	0.5	80%	88%
Alternative 6 – UCT Process	28	4.5	5	0.7	81%	84%
Alternative 7– Two-Pass A ² /O Process	28	4.5	7.5	0.4	73%	91%
Alternative 8 – Two-Pass Modified Bardenpho Process	28	4.5	5	0.4	83%	91%

Selected Method – Two-Pass A²O

- ▶ Process schematic – two basins

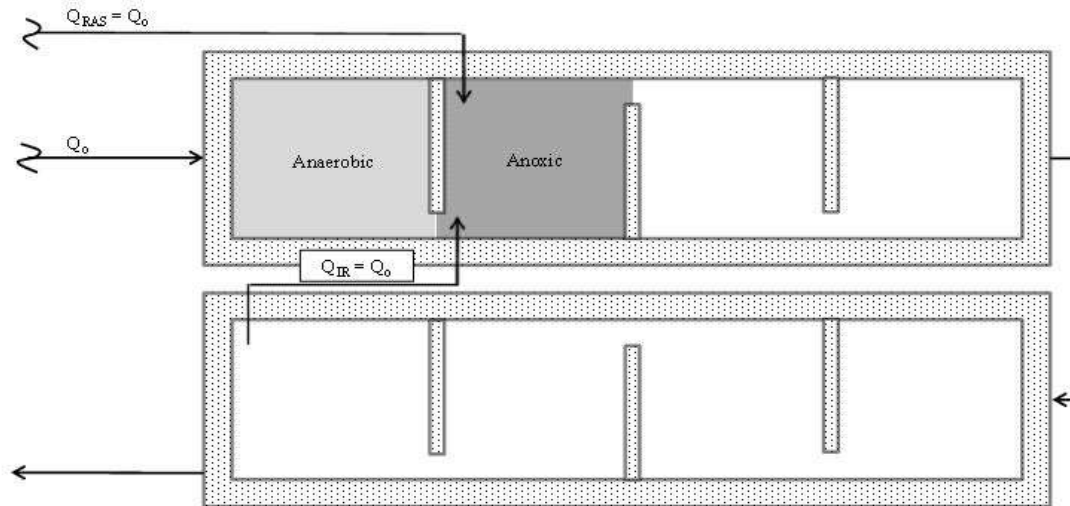

- ▶ Advanced nitrogen and phosphorus removal
- ▶ Nitrate recycle
- ▶ Anaerobic and anoxic basins with mixers

BNR Design

Plant Modifications

Blower replacement

Aeration basin modifications

- ▶ Basin structural changes
- ▶ Extension of piping to flip basins
- ▶ Mixer installations
- ▶ Recycle pumps and piping addition
- ▶ Flow meters, sensors, and air valves added

Chemical feed system (backup system)

Building modifications

SCADA system, sensors, and controls



Aeration Basin Layout

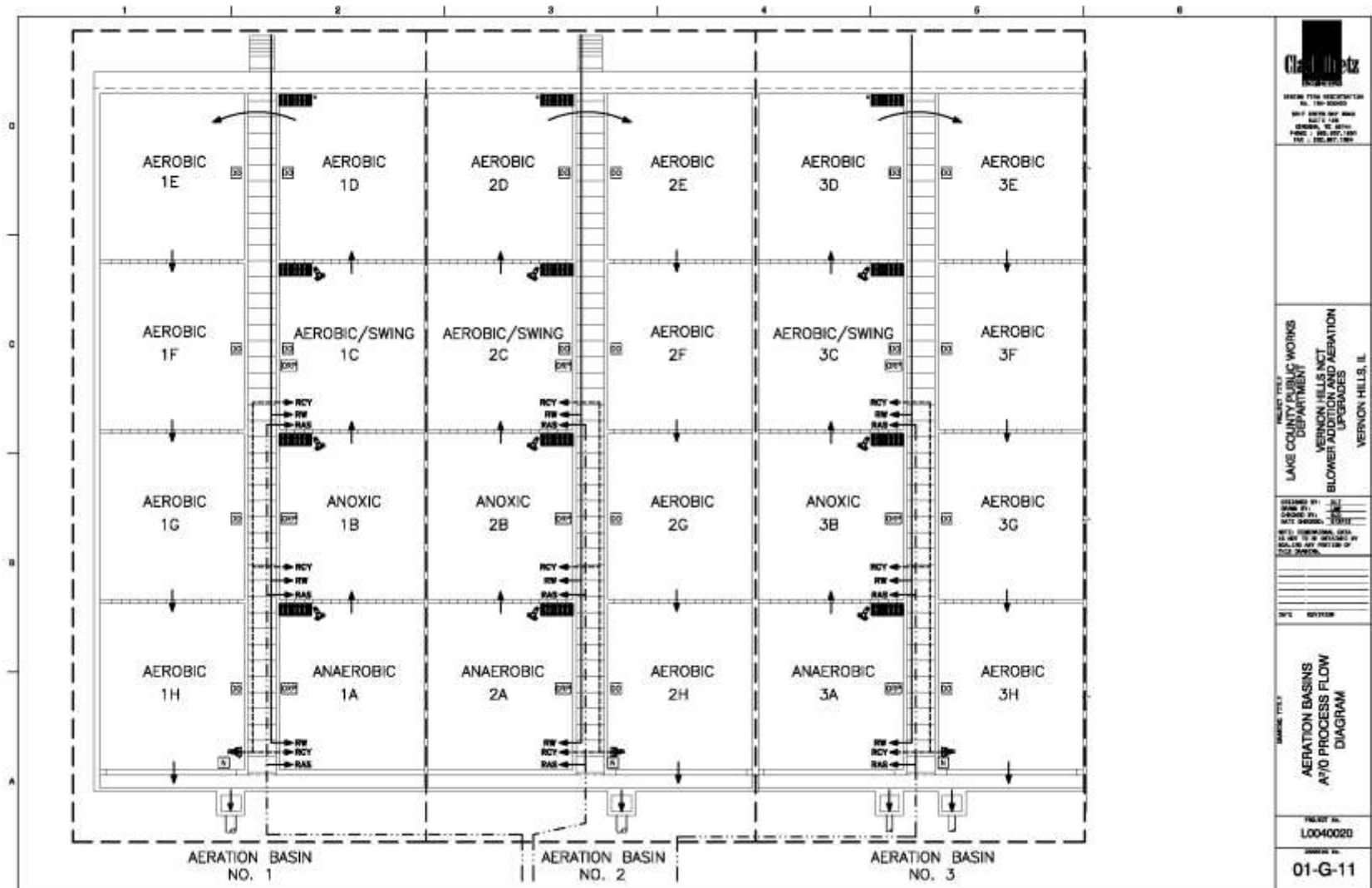

BNR System Operation

Current Operation

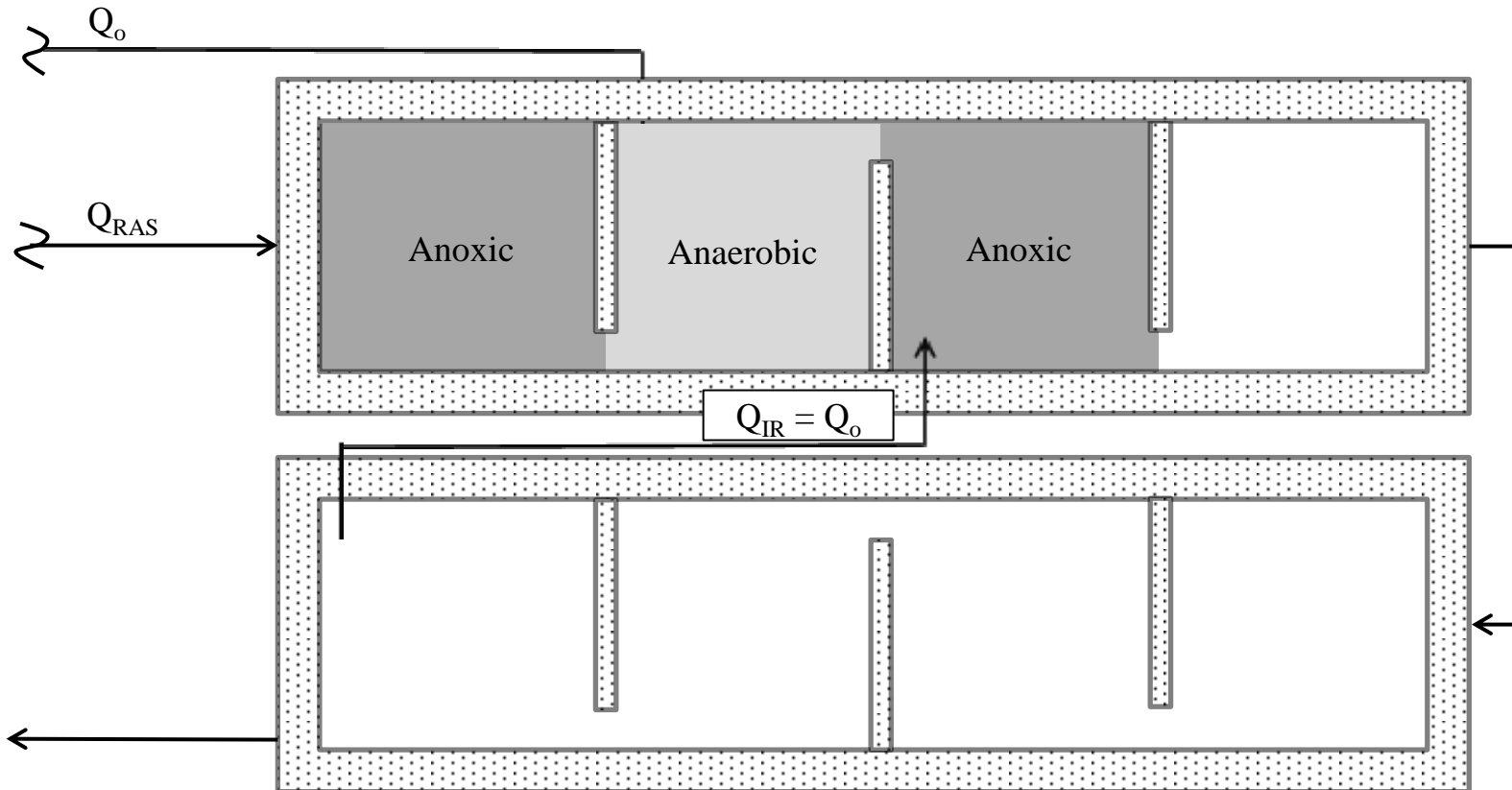

Process Flexibility

1. Modulating air valves with individual DO sensors
2. Ammonia and nitrogen sensors
3. Aerobic/anaerobic and swing cells
4. Mixers regulated by both ORP probes and timers
5. Nitrate recycle pumps/piping with VFDs
6. Effluent phosphorus analyzer

Process Control

- ▶ New Master Control Center



Treatment Results

Average Concentration June 2015

	Phosphorus, mg/L	Total Nitrogen, mg/L
Influent	4.414	19.7
Effluent	0.086	7.1

Predicted Energy Savings

Power Use and Cost Estimates

	Existing	BNR
Connected Blower Hp ¹	300	200
Operating Blower Hp ²	300	100
Mixer Hp	--	30
Recycle Pump Hp	--	15
Total Operating Hp	300	145
Daily Operating Hours	24	24
Daily Energy Use, kW-hr/day	5,371	2,596
Annual Energy Use, kW-hr	1,960,488	947,569
Annual Energy Saved, kW-hr		1,012,919
Power Cost (Actual), \$/kW-hr	0.07	0.07
Power Cost (DCEO), \$/kW-hr	0.12	0.12
Annual Energy Cost (Actual)	\$137,200	\$66,300
Annual Energy Cost (DCEO)	\$235,300	\$113,700
Annual Energy Savings (Actual)		\$70,900

Notes:

- (1) One blower is in operation in each aeration scenario. The new blower was sized to meet the current peak day demand.
- (2) It was assumed that the VFD on the new turbo blower will be turned down to 50 percent of capacity to meet average day aeration demands.

Actual Energy Use

Total Plant Power Use, 2014 - 2015

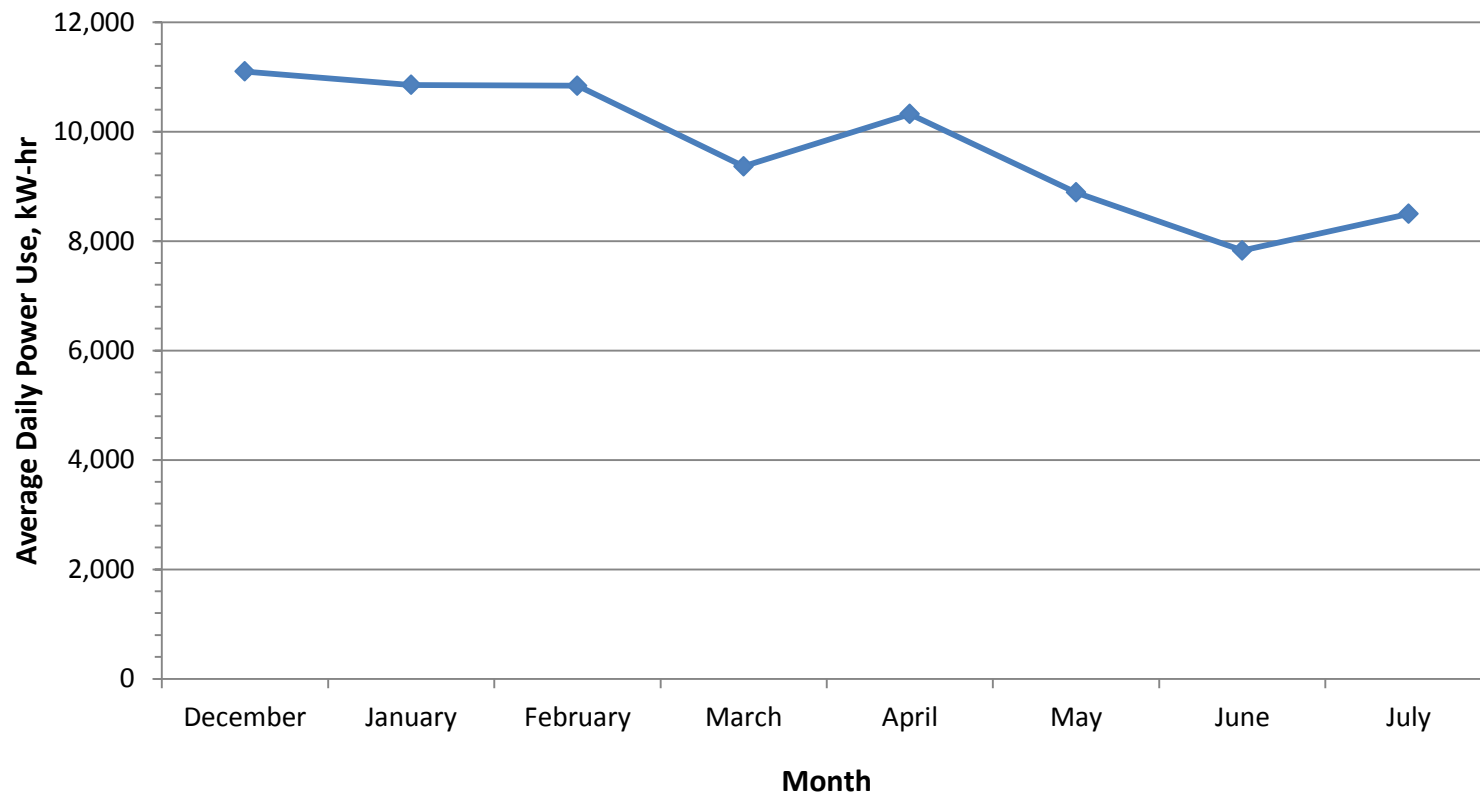

Energy Savings Grants

- ▶ DCEO Grant - \$121,600
- ▶ Illinois Clean Energy Grant - \$231,550
 - Based on units of energy saved
- ▶ Wisconsin energy savings grants available through Focus on Energy



Final Thoughts

1. Energy savings are available in your plant
2. Advanced nutrient removal might be possible, too
3. Detailed analysis and modeling required
4. Perform an energy audit
5. Check funding availability



Questions?

Diane Thoun, P.E.

Phone: 262.657.1550

Email: Diane.Thoun@clarkdietz.com

