

Current Trends in Biosolids Management & Treatment

35th Annual
Spring
Biosolids
Symposium

March 21, 2017
Stevens Point, WI



Jay Kemp, PE, BCEE
Black & Veatch

Bill Marten, PE, BCEE
Donohue & Associates

Presentation Topics

High Level Overview Discussion of:

- **Digestion**
 - **Aerobic**
 - **Anaerobic**
- **Nutrients**
 - **Issues, Challenges, Recovery**
- **Takeaways**

Aerobic Digestion

Aerobic Digestion Has Been Around a Long Time, What Could be New or Trending?

- **Operational Mode Cycling**
 - **Cycling Air On (Aerobic) and Off (Anoxic)**
- **Use of Membranes to Enhance Thickening**

Operational Mode Cycling

- **Can Accomplish in Dedicated Reactor Zones or Single Reactor (Digester)**
- **Aeration ON**
 - Digestion occurring
 - Oxygen is utilized for electron acceptor
 - Ammonia is nitrified to nitrate
 - Alkalinity is consumed & pH decreases
- **Aeration OFF**
 - Digestion occurring
 - Nitrate is utilized as electron acceptor (Energy Savings)
 - Nitrate is denitrified to nitrogen gas
 - Alkalinity is recovered & pH increases

Aerobic Digestion Cycling

- **Process Control**

- **Aerobic: D.O. or Time**

- **Anoxic/Anaerobic: ORP or Time**

- > **Experiences Have Shown 50/50 Time Split Works Well**

- **Can Minimize Digested Sludge Production**

- **Long Cycle Times and Multiple Cycles in Each Operational Mode**

- > **Similar to Interchange Reactor Effect of the Cannibal Process**

- **Enhanced Digestion Due to More Effective Predation**

- > **Anaerobic Predation on Aerobic Organisms**

- > **Aerobic Predation on Anaerobic Organisms**

Aerobic Digestion: Membrane Thickening

- **Eliminate Decanting, Use Membrane Filters for Solids Separation (Decanting)**
- **Benefits**
 - **Cleaner “Decant”**
 - **Ability to Operate Digester at Much Higher TS Concentrations**
 - > **From Typical 3% TS to 4.5-6% TS**
 - > **Increases Treatment & Biosolids Storage Capacity, Possibly Delaying Need for Plant Expansions**

Aerobic Digestion: Membrane Thickening

Example: Kubota PAD-K Aerobic Digestion

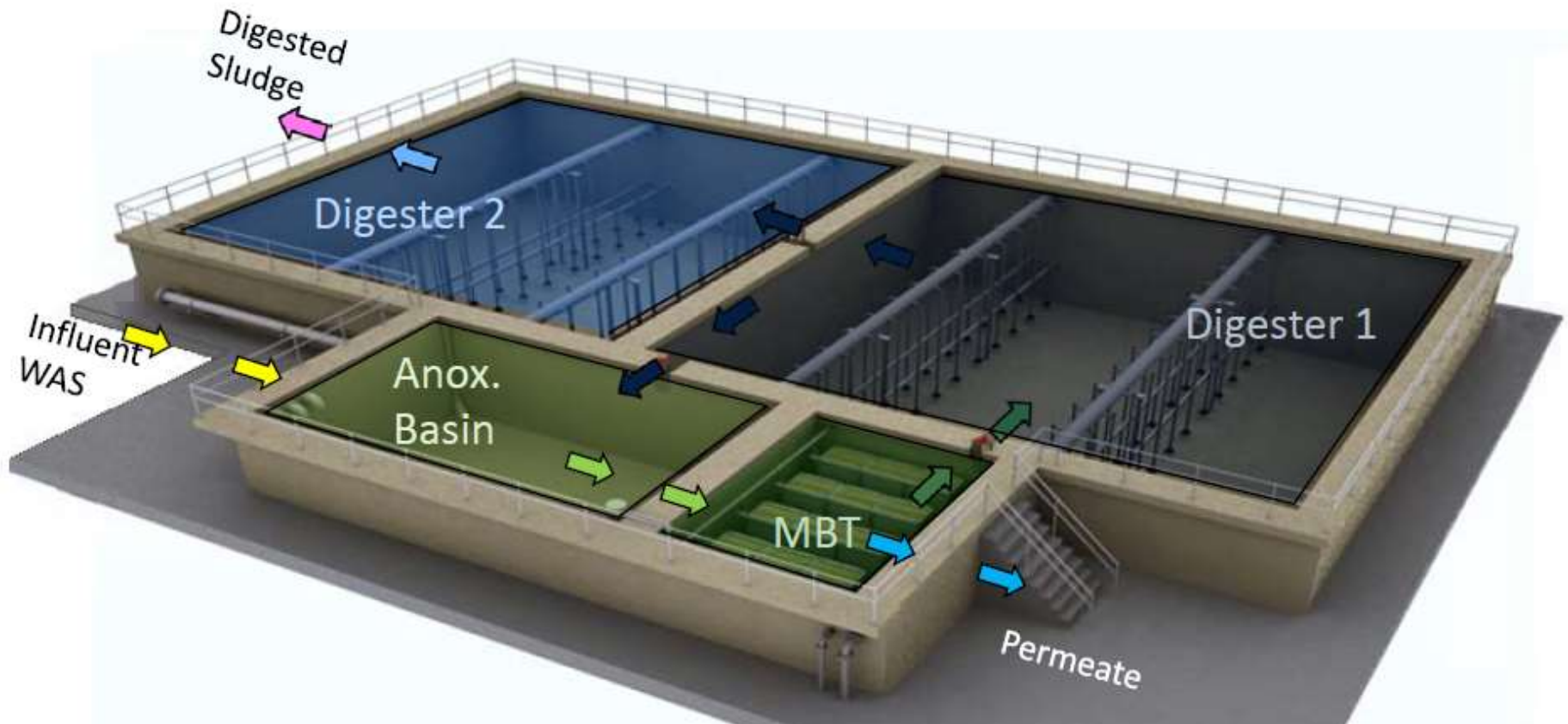

Anaerobic Digestion Trends

- **Maximizing Biogas Production & Energy Use/Value**
 - High Strength Waste Receiving
 - Effective Mixing
 - Recuperative Thickening
 - Staged Digestion
 - *Pre-Digestion Sludge Treatment*

Pre-Digestion Raw Sludge Treatment

- **Electrical Pulses**
- **Mechanical Grinding**
- **High Heat**
 - **With Pressure**
 - **With Chemical Treatment**

Pre-Digestion Raw Sludge Treatment

- ~~▪ Electrical Pulses~~
- ~~▪ Mechanical Grinding~~
- High Heat
 - With Pressure
 - With Chemical Treatment



Heat & Pressure Approach

- **Cambi Thermal Hydrolysis**

- Pre-Dewatering
- All Sludge or Just WAS

- **BioThelys**

- Pre-Dewatering
- All Sludge or Just WAS

- **Exelys**

- Pre-Thickening
- Usually Just WAS

In General:

- **Utilize Steam**
- **Raise Sludge Temperature to 330-350 Deg F**
- **Raise Pressure to 90-130 psi**
- **Rapid Depressurization**
- **All Capable of Class A**

Example Heat & Pressure: Exelys

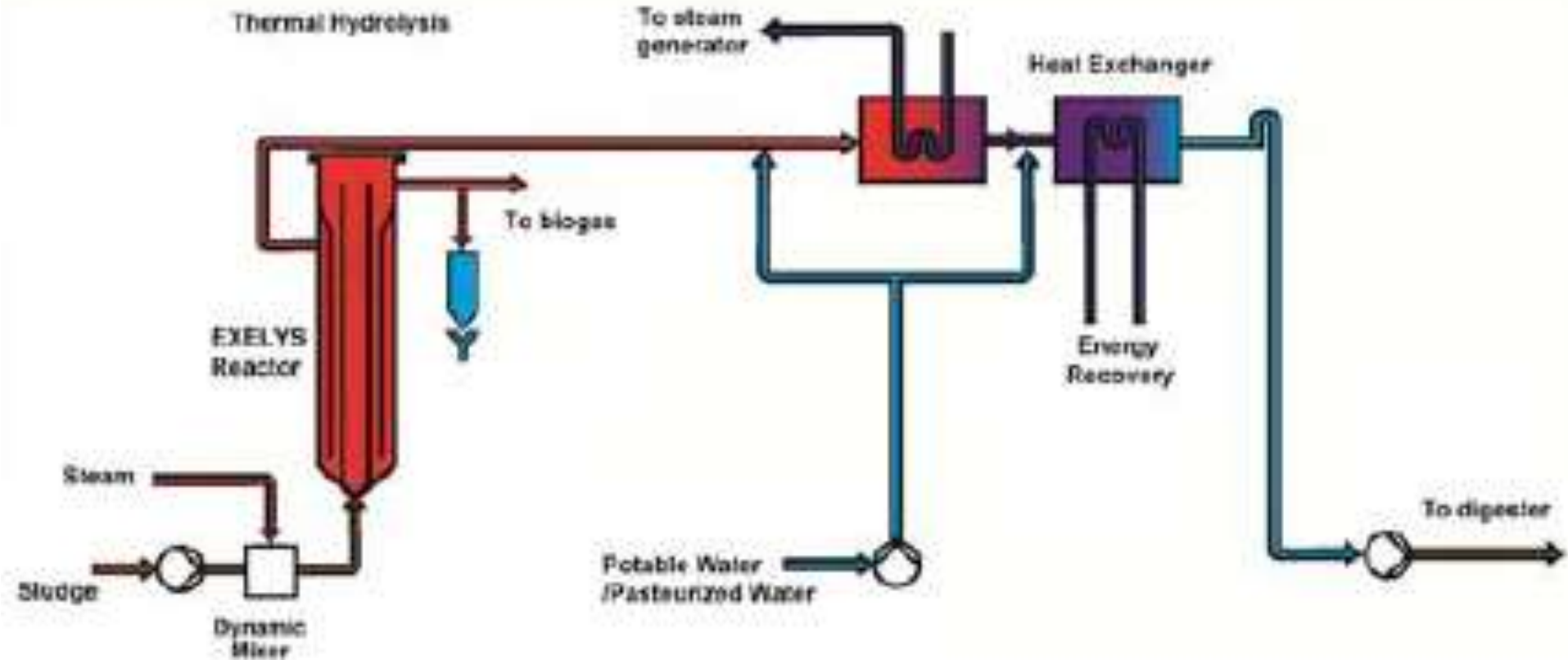

Heat & Chemical Approach

- **Pondus TCHP**

- **Pre-Thickening**
- **All Sludge or Just WAS**

In General:

- **Utilize Hot Water**
- **Raise Sludge Temperature to ~150 Deg F**
- **Use Caustic to Raise pH to ~11**
- **Hydrolization Lowers pH**
- **Capable of Class A**

Example Heat & Chemical: Pondus TCHP

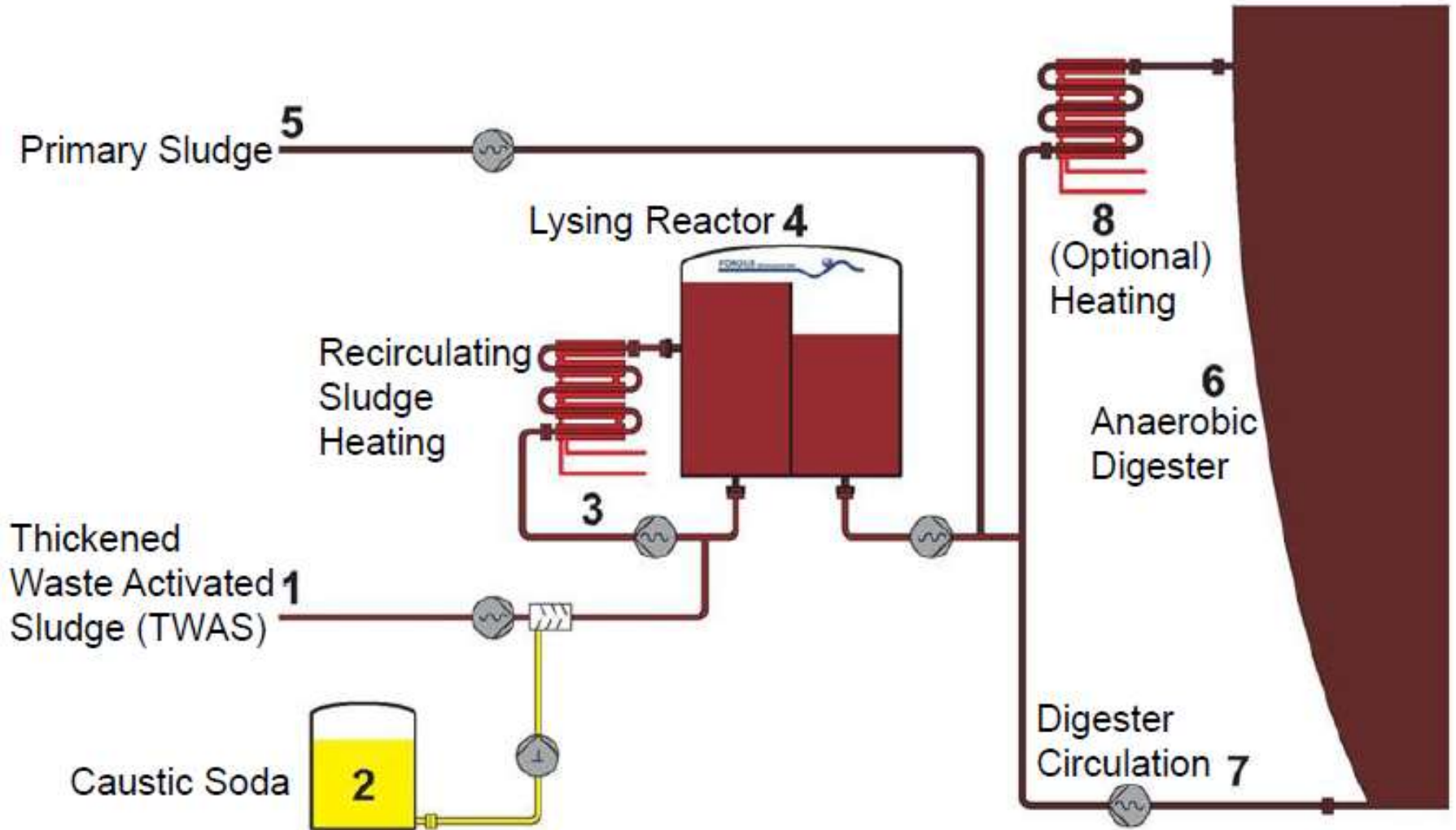

Pre-Digestion Treatment Considerations

- **Process Complication vs Operating Costs**
 - Dewatering vs Heating Water
- **Total Present Worth Considerations**
 - Capital Cost
 - Operating Cost Negatives
 - > Heat, Chemical, Processing Energy
 - Operating Cost Positives
 - > Increased VSR of 10-20% Possible
 - > Potential Class A

***Performance characteristics will be highly site specific
– pilot testing recommended.***

Nutrient Issues/Challenges

Nutrient Issues/Challenges: Phosphorus

Nutrient Issues/Challenges: Phosphorus

- **NR 217: 20+ Years of Effluent P Limits**
- **Biosolids Impacts**
 - Higher P Content
 - Increased Sludge Quantities

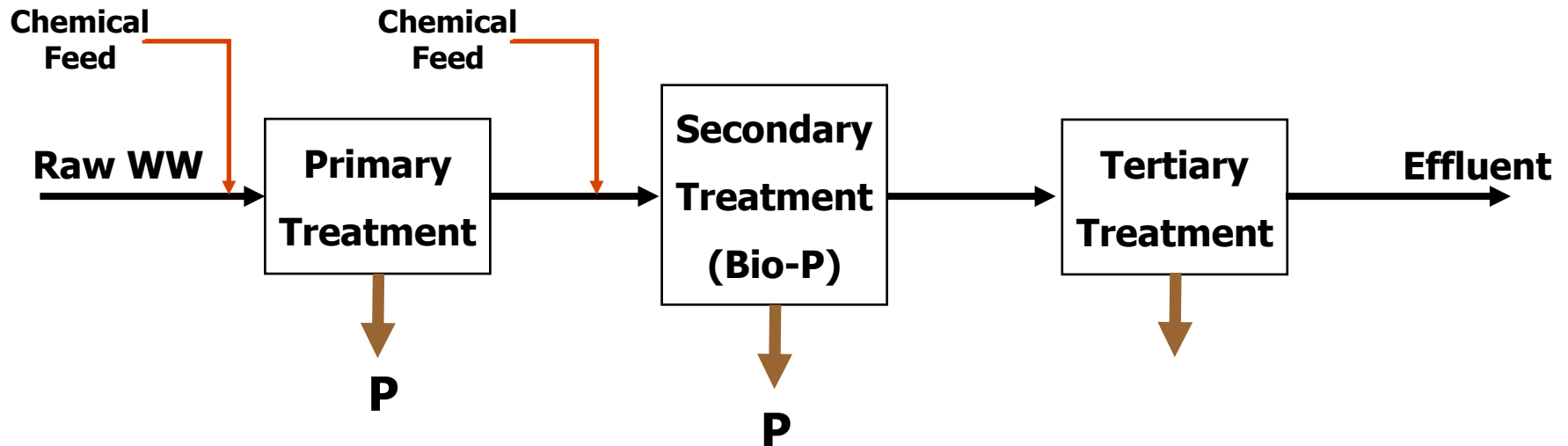

Revisions to NR 217 – A New Pinch on P

- **Very Low Water Quality Based Effluent Limits Will Result in:**
 - Higher Levels of Removal Required
 - Alternative Compliance Approaches such as Trading, Adaptive Management, Variances

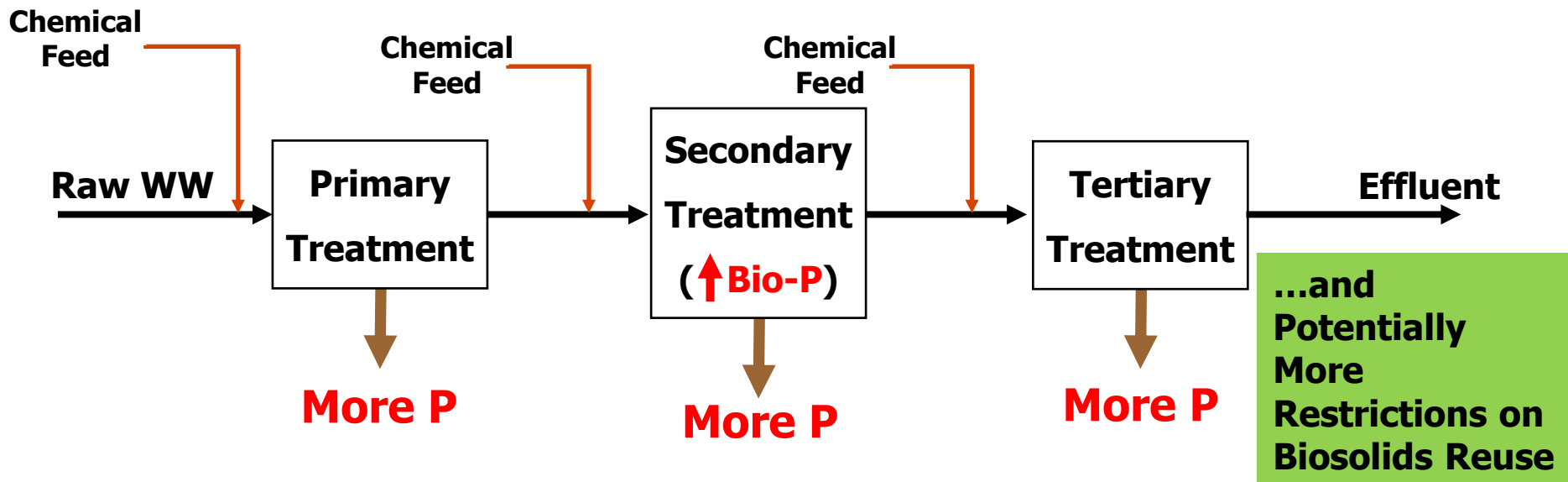

Bio-P Presents Some Unique Biosolids Challenges...

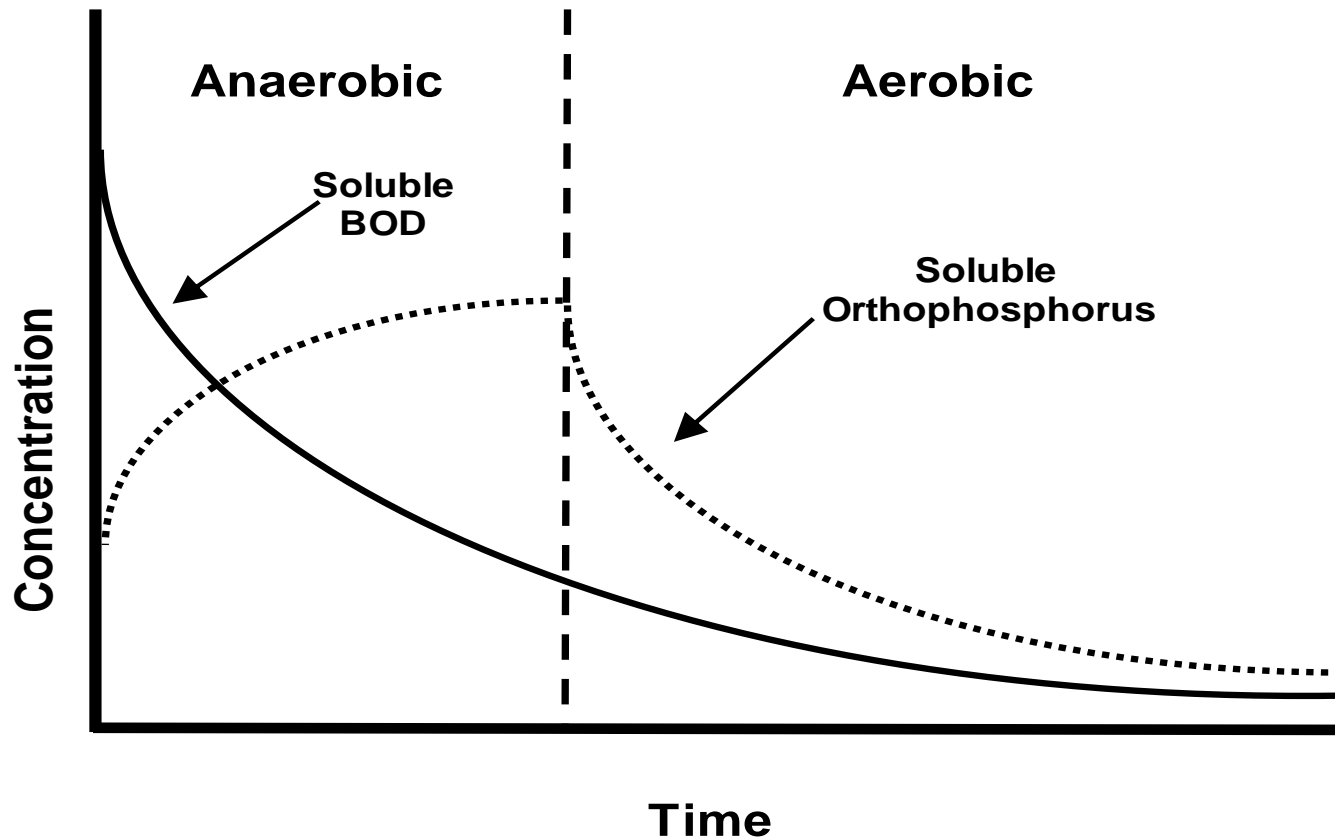

...Due to the Required Anaerobic/Aerobic Cycling

Bio-P Refresher...

Anaerobic Zone => VFA Uptake & SP Release

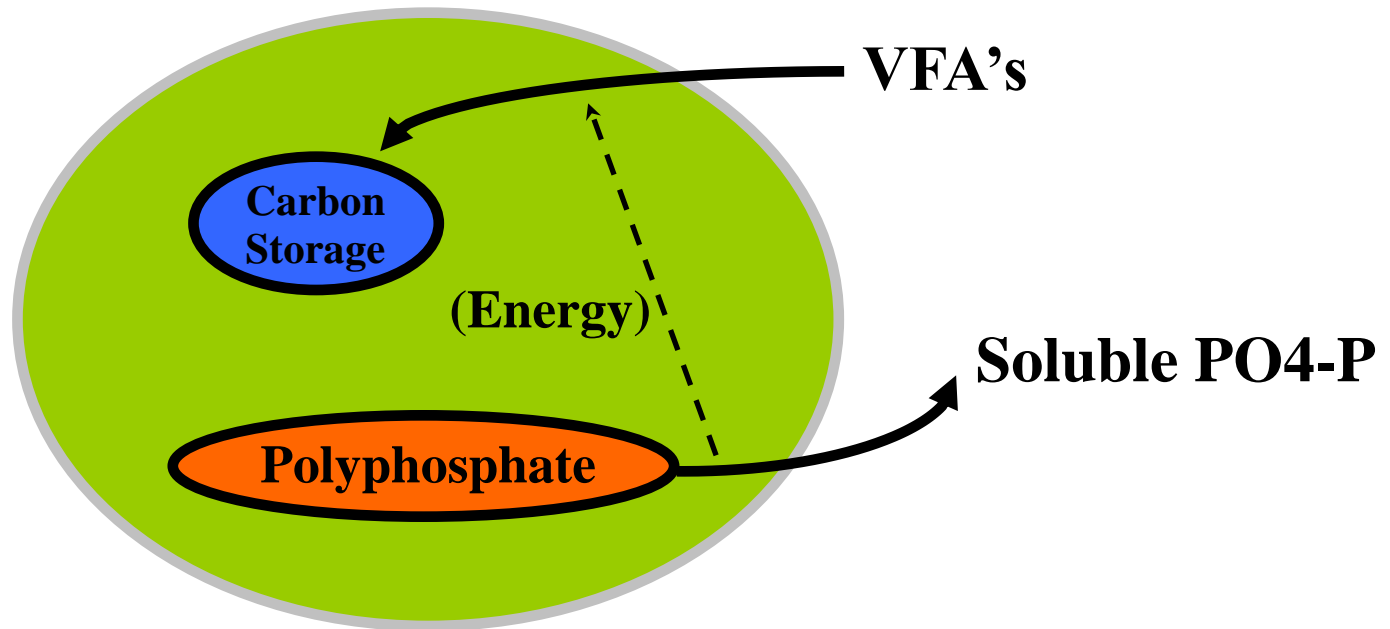

Bio-P Refresher...

Aerobic Zone => Biometabolism of Carbon (Growth & Oxidation) & Soluble P Uptake

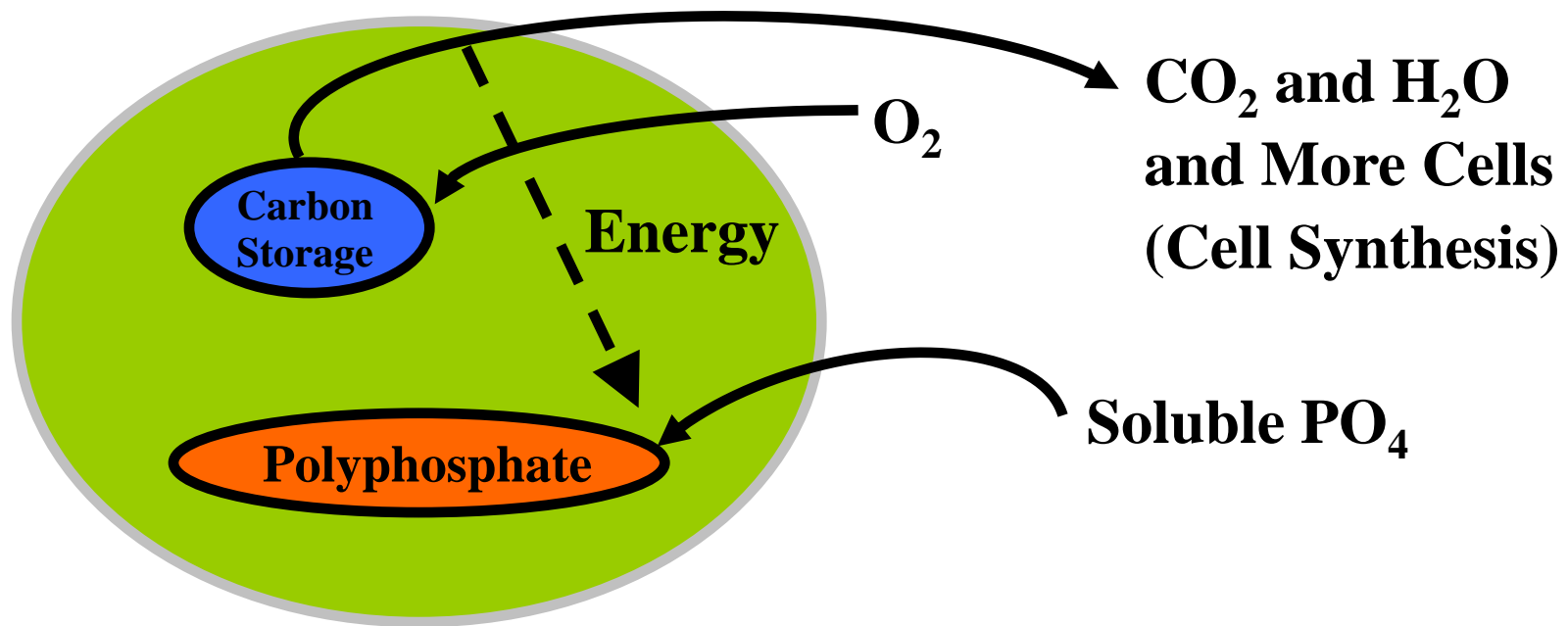

Most Bio-P Related Biosolids Challenges Are Associated With Anaerobic Digestion

Anaerobic Conditions with Lots of VFAs

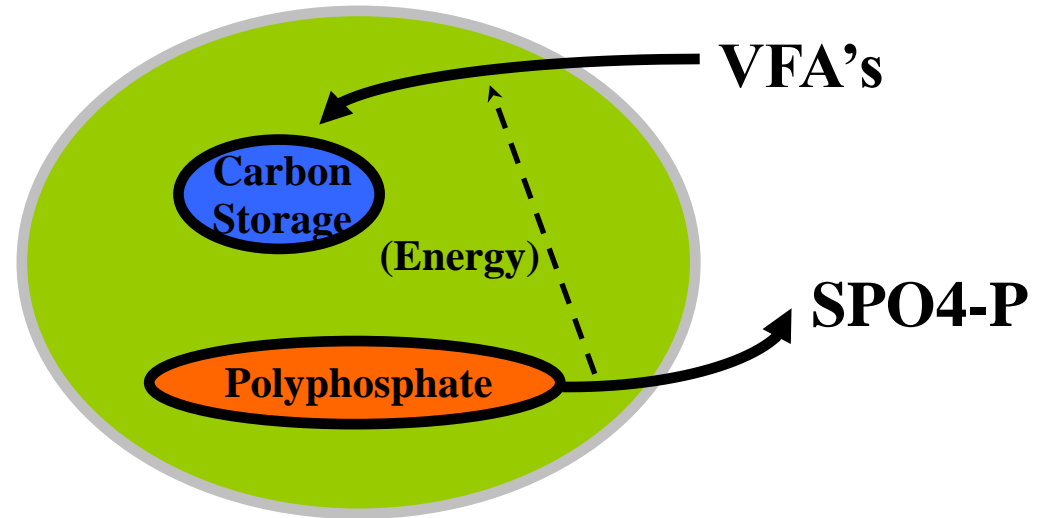

- **Soluble P₀₄-P Release**
- **Thickening/Dewatering – Increased SPO₄-P in Filtrate/Centrates Sidestreams**

Increased SPO₄-P Also Occurs With Aerobic Digestion, Just Not to Same Extent

One (Now Familiar) Bio-P/Anaerobic Digestion Sidestream Issue...Struvite!

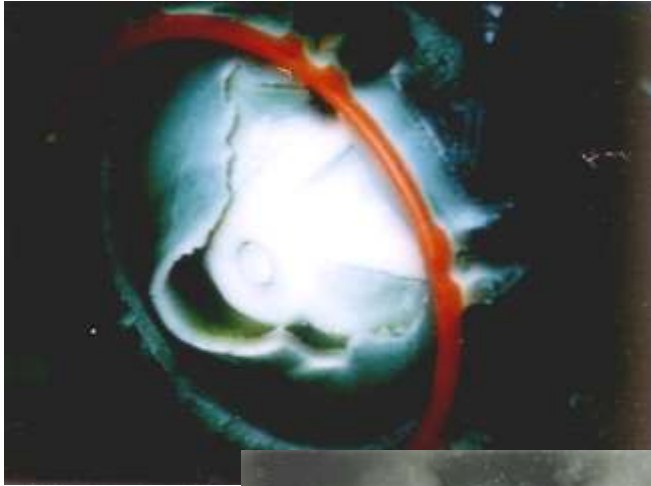

Luckily, We Understand Struvite & Controlling It

- **Sidestream Control Strategies Can Also Control Struvite**
 - Or Simple Dilution of Filtrate Can Work Too

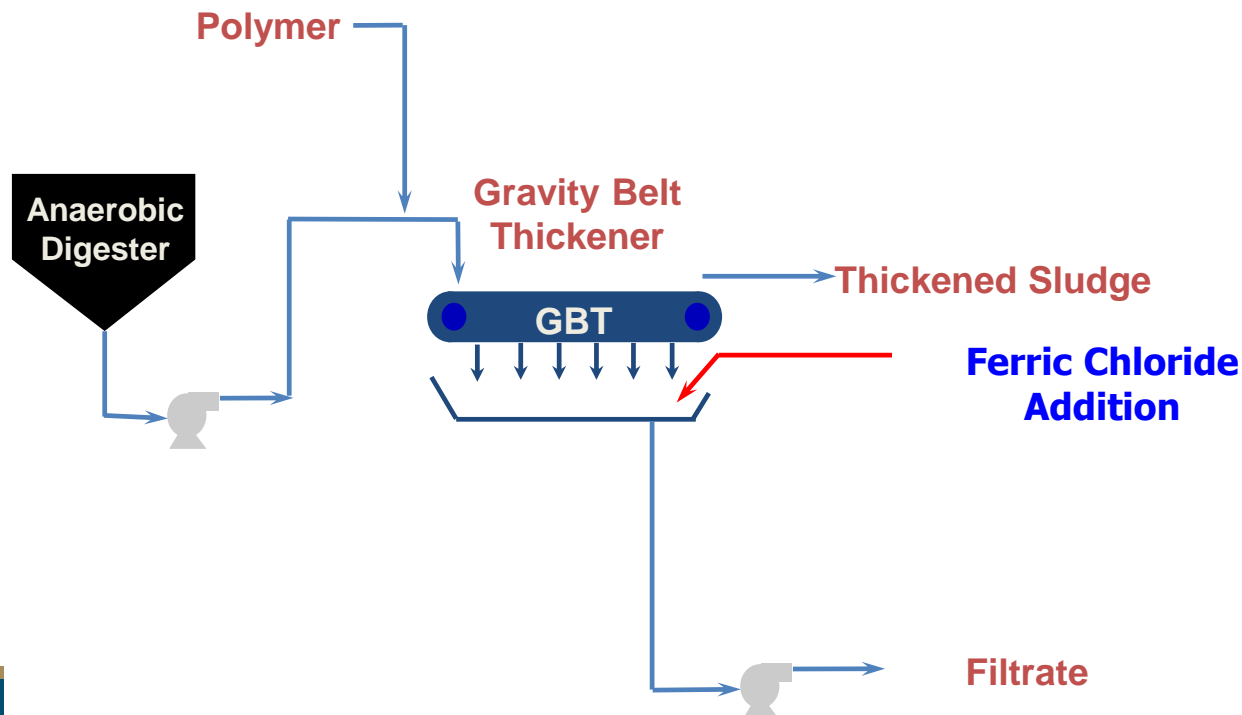

Such Sidestream/Struvite Control a Standard Component of Our Designs



- Eau Claire DSD Thickening Filtrate Line

The New Bio-P Ugly: Impaired Dewatering of Anaerobically Digested Sludge



Impaired Dewatering of Anaerobically Digested Bio-P Sludge Observations

- **Dewatered Cake “Looks Normal & Dry”**
- **Reduction in Cake Dryness of 5-8% TS**
- **Stacking Height Often Half of Expected**
- **Being Experienced at Many Plants**
 - **Beloit, WI**
 - **Sun Prairie, WI**
 - **Marquette, MI**
 - **Hampton Roads Sanitary District Atlantic & Nansemond Plants, VA**
 - **Met Council Environmental Services Empire & Blue Lake Plants, MN**
 - **Metro Denver, CO**

Suspected Causative Factors

- **Differences in Extra-Cellular Polymeric Substances (EPS)/Soluble P Concentration of Digested Sludge**
 - **Evidence that soluble Ortho-P binds water to solids**
 - > **Possibly due to increased presence of EPS/EPS binds water**
 - > **Lower digested sludge soluble Ortho-P => higher cake TS**
- **Divalent Cation Bridging**

Divalent Cation Bridging Theory

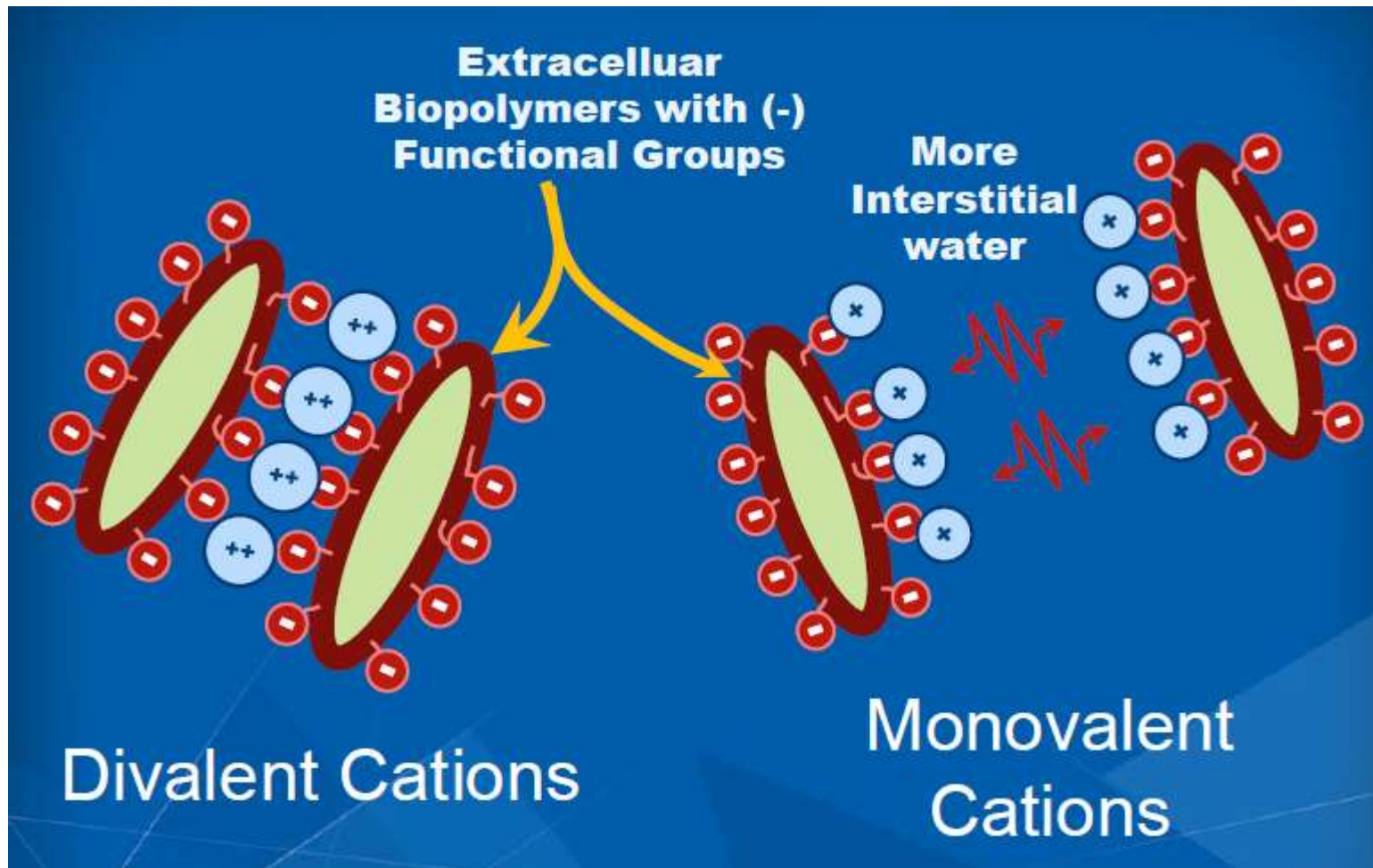

Courtesy of Sprouse, 2013

Divalent Cation Bridging Theory

- **Prominent Divalent Cations Are Mg^{2+} , Ca^{2+} and Fe^{2+}**
- **Prominent Monovalent Cations are Na^{+} and K^{+}**

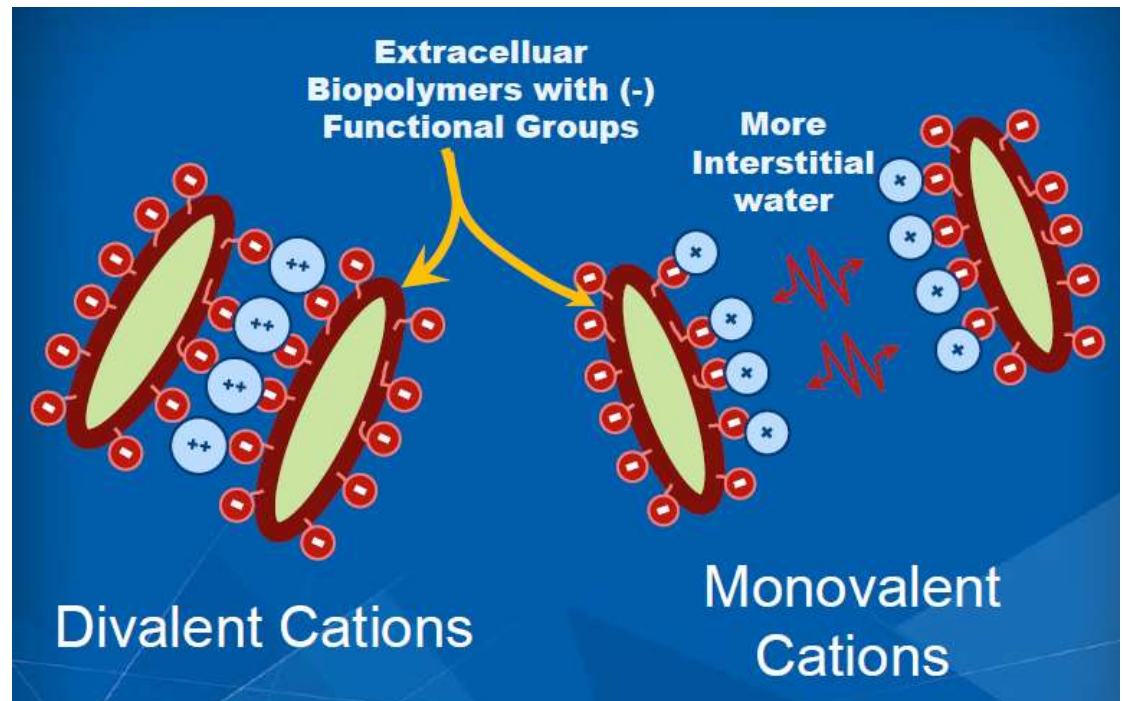

To Help Understand This, Let's Take a Step Back

Anaerobic Digestion of Bio-P: Potential Effect on Cation Ratios

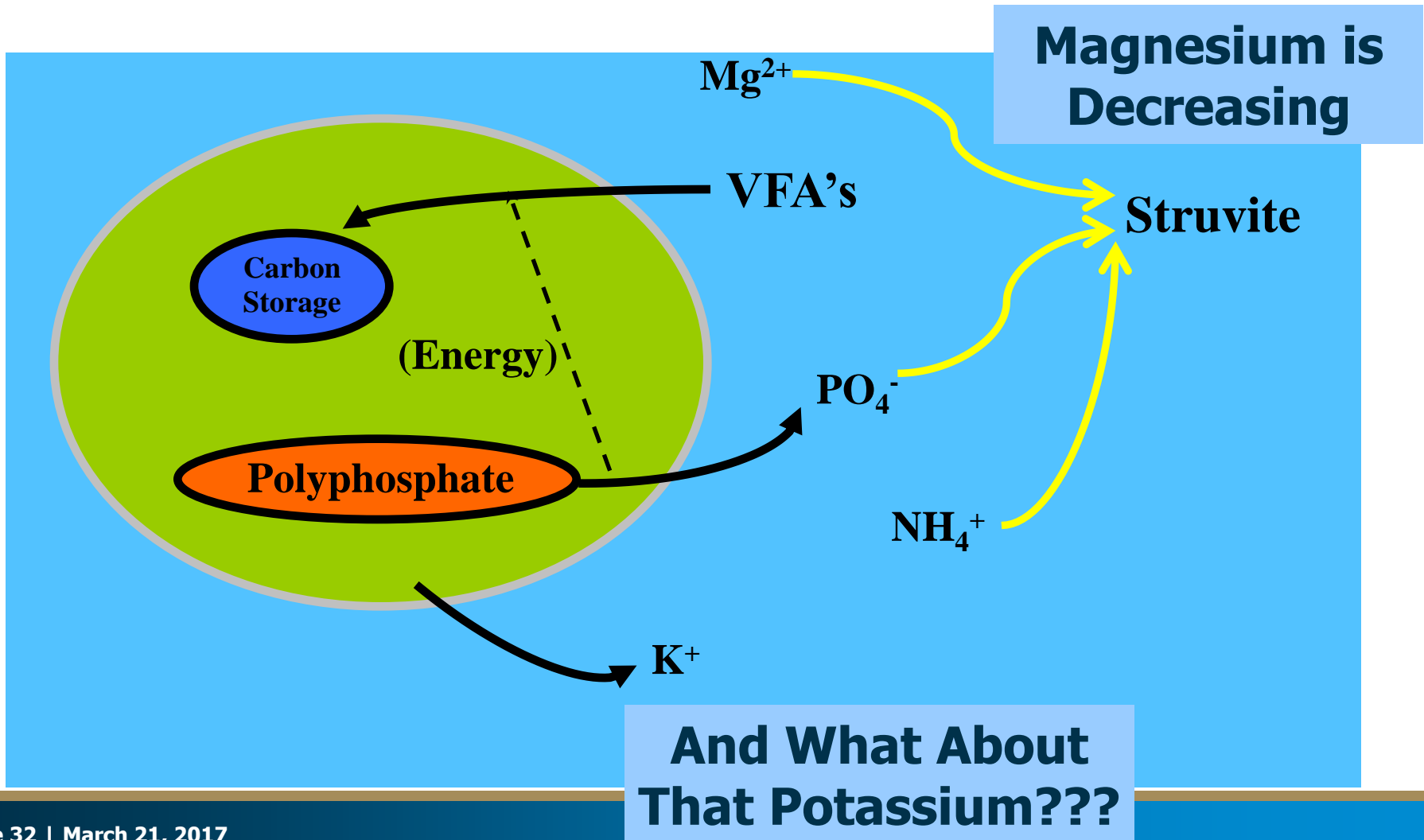

An interesting development is struvite harvesting and claims it can help solve this problem.

The approach involves making struvite intentionally to:

- **Minimize Impacts on Cation Ratios**
- **Minimize Soluble P Content**

Before the digested sludge gets to dewatering.

One Example: Airprex



Pilot Testing at Several Wisconsin Plants in 2016 Has Shown Dewatered Cake Gains of 2-5% TS

Airprex is making struvite before dewatering. But is the improvement due to less soluble P in the sludge, or more divalent cations???

Example: Pilot Testing Airprex at Stevens Point May 2016

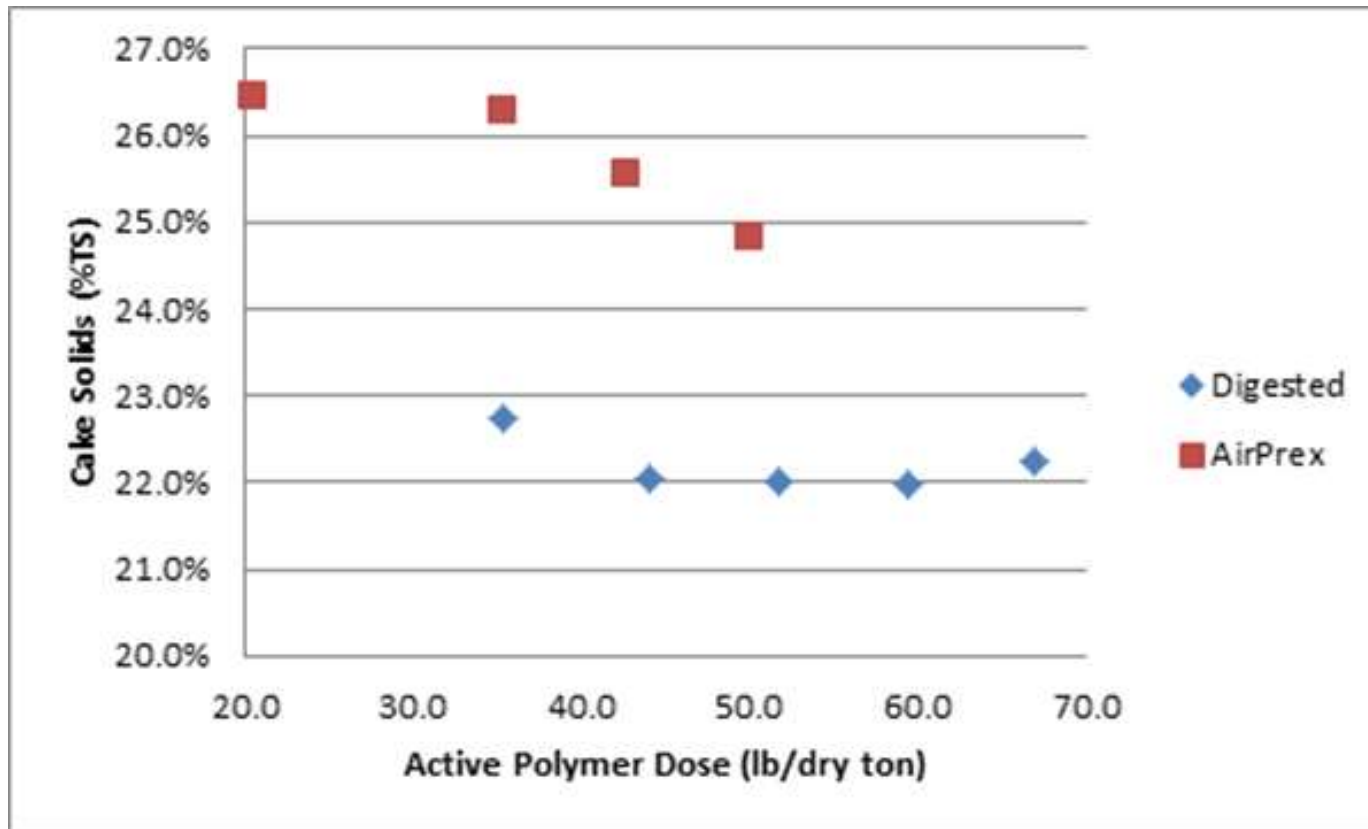

4-5% TS Increase with Airprex

Highly Site Specific: Pilot Testing Needed

Nutrient Recovery Discussion Items

Nutrient Recovery Discussion Items

- **Nitrogen-phosphorus balance in biosolids**
- **P-index**
- **Benefits of phosphorus removal from biosolids**
- **Background on Struvite and Brushite Solubility**
- **Alternatives for phosphorus removal**

Biosolids are Applied based on nitrogen requirements

- **Typical digested sludge**
 - 5 % N; 2% P
- **Bio-P Sludge**
 - 5% N; 4 % P
- **Application based on N may apply P in excess of crop requirements**

How much P from biosolids is plant available ?

- **Area of active research**

- **WERF Study**
- **UW- Madison**
- **WI Lutheran College**
- **Penn State**

- **P-index**

- **Considers how P is delivered to surface water**
- **Considers all sources of P**

Wisconsin P Index

**P Index estimates delivery to nearest surface water;
Accounts for sources and transport based on
long-term average weather**

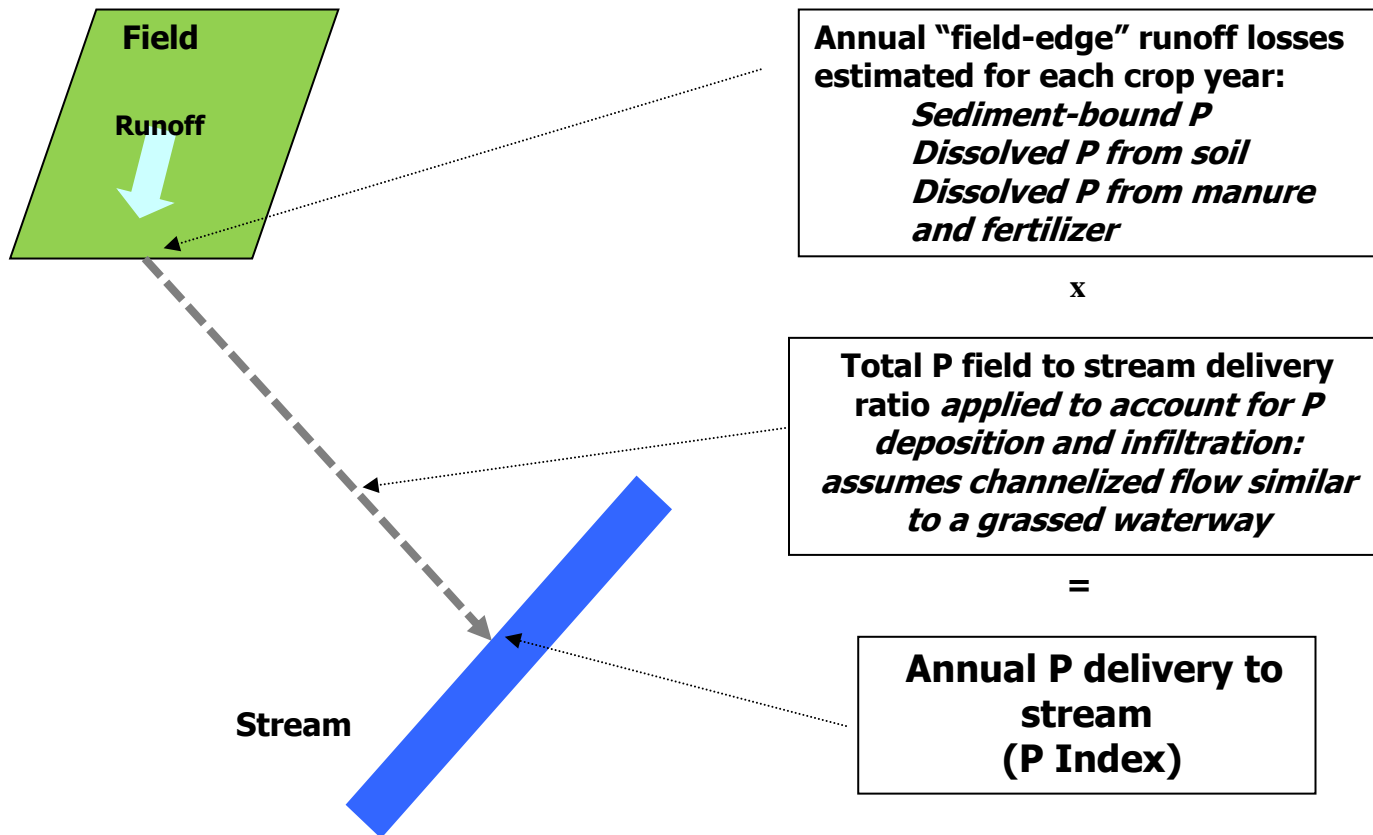

Sources of Phosphorus in Runoff

- **Soil P**

- Biosolids may increase soil P
- Bound P- may solubilize over time

- **Manure P on surface**

- **Fertilizer P on surface**

P Index: Field-Specific Estimate of Total Average Annual Runoff P by Source and Transport Pathway

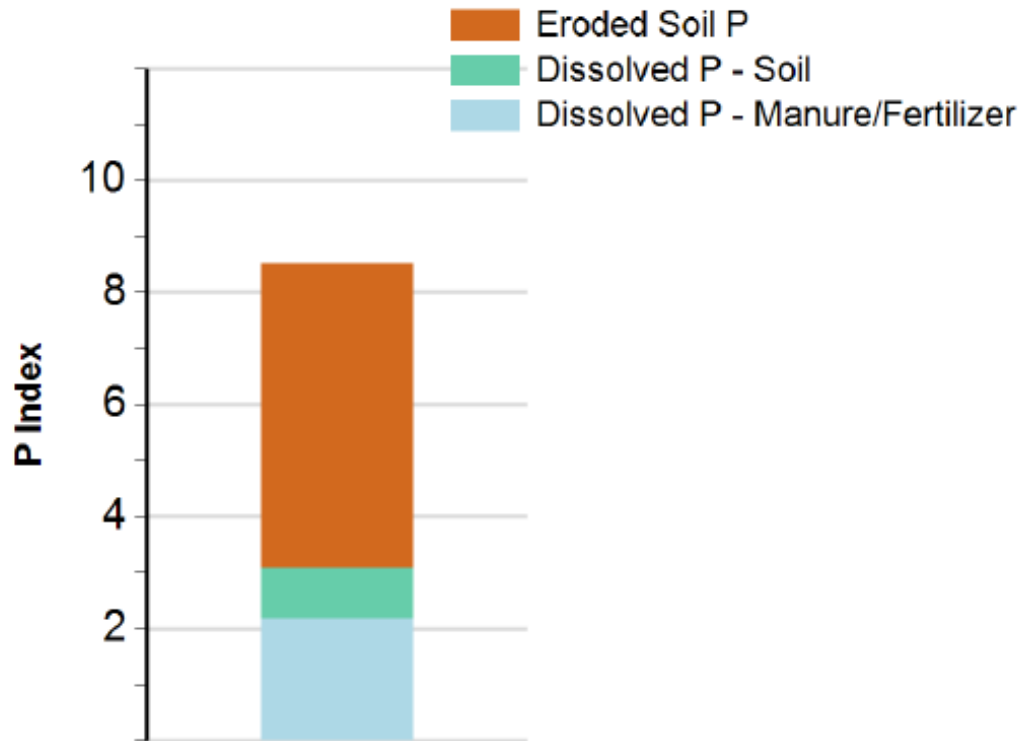

Total runoff P losses are a function of amount of P in soil and surface amendments and the amount of runoff and erosion

Benefits of phosphorus removal

- **Decrease P content of biosolids**
- **Improve biosolids dewaterability**
- **Minimize nuisance scaling and deposits**
- **Reduce P & N recycle loads**
- **Recover fertilizer product**

P must be insoluble to remove or recover

- **Iron salts (ferric chloride) do not produce a recoverable product**
- **Struvite and brushite recover P as useable fertilizer**
 - **Struvite Mg-NH₃-P**
 - **Brushite CaHPO₄**
- **Divert a valuable resource to where it can be used**

Struvite Solubility

- Struvite less soluble above and below 35 °C

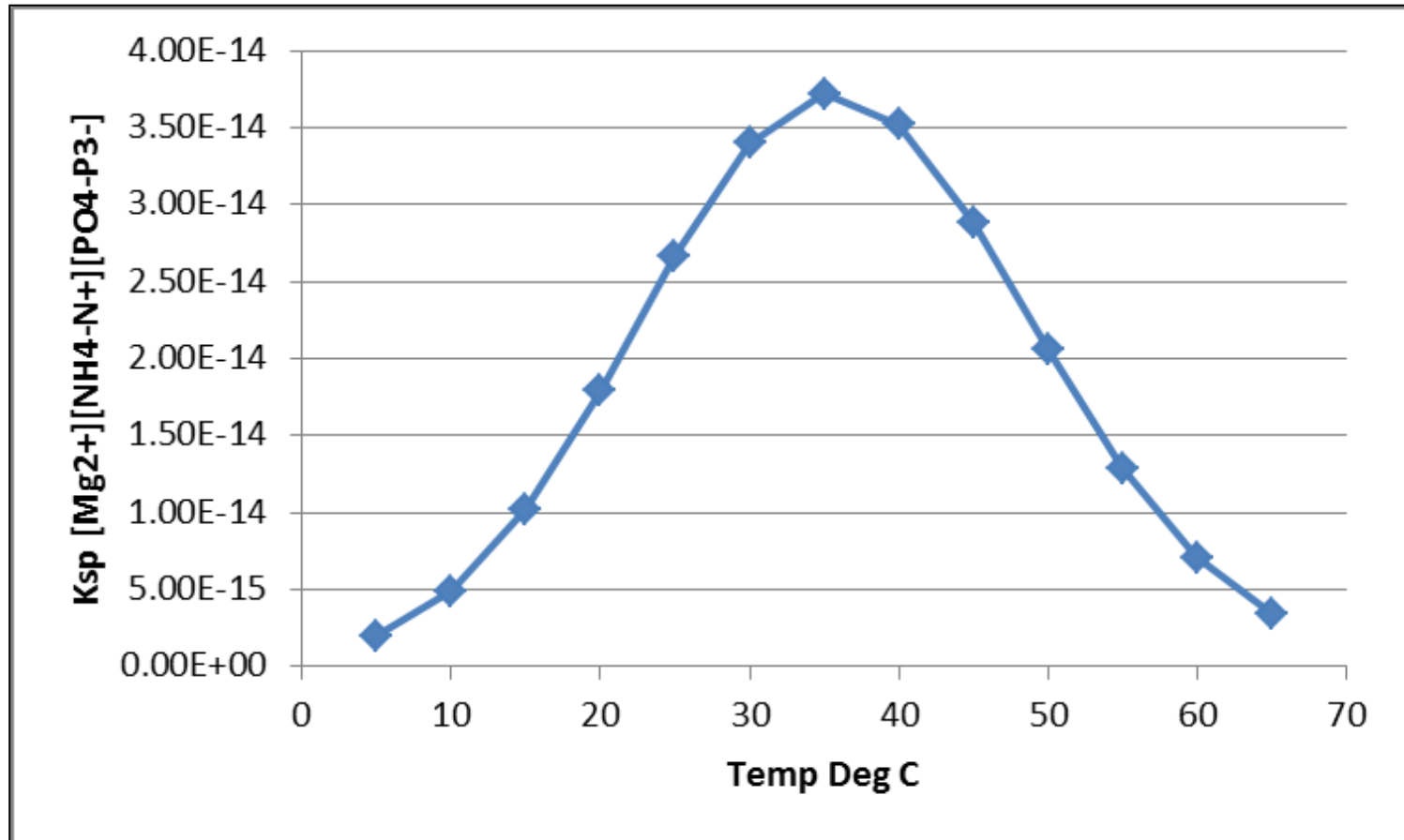

MD. IQBAL HOSSAIN BHUIYAN

M.Sc, UENSCO-IHE Institute for Water Education, 2002

Brushite Solubility

- High PO₄-P and Ca in acid phase digestion

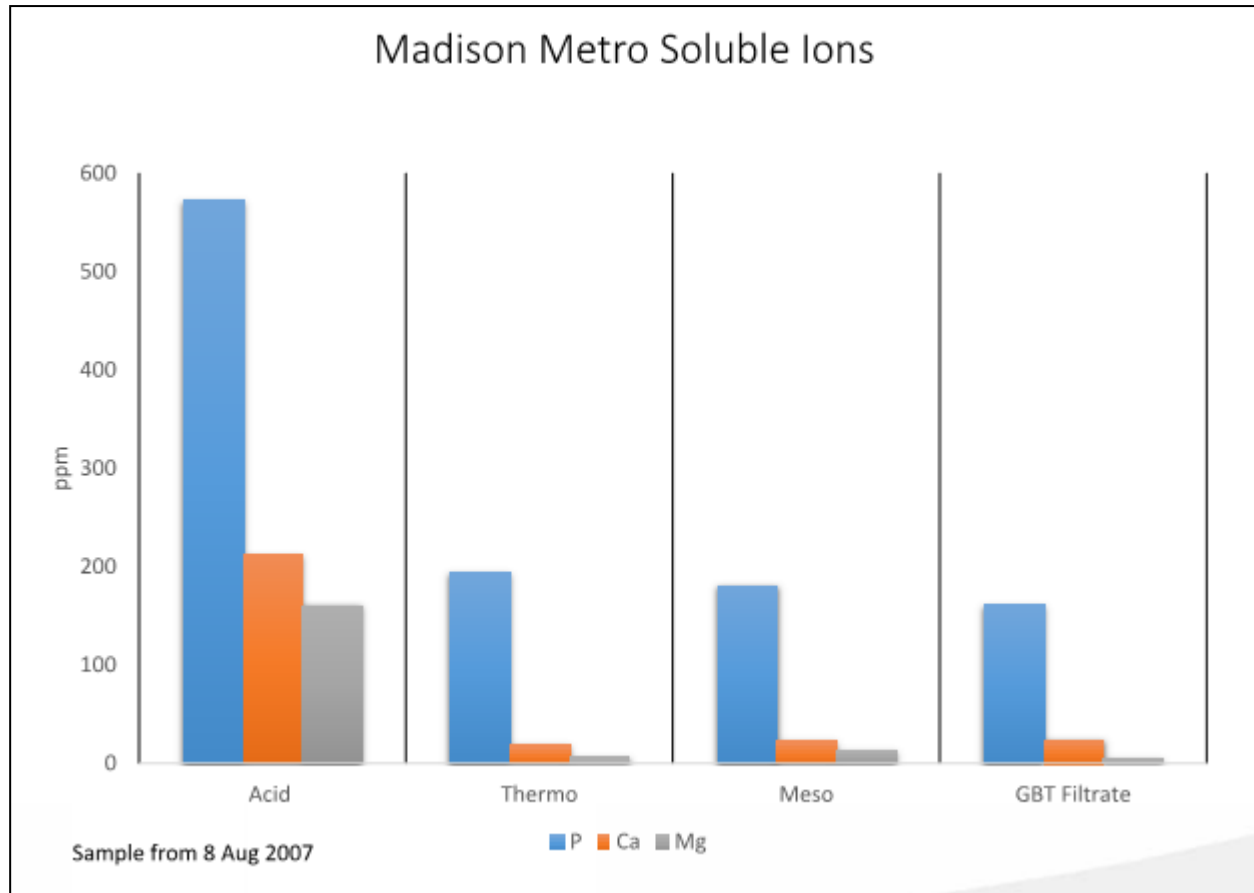

Brushite Solubility

- $\text{CaHPO}_4 \cdot 2\text{H}_2\text{O}$ Precipitates at acid conditions

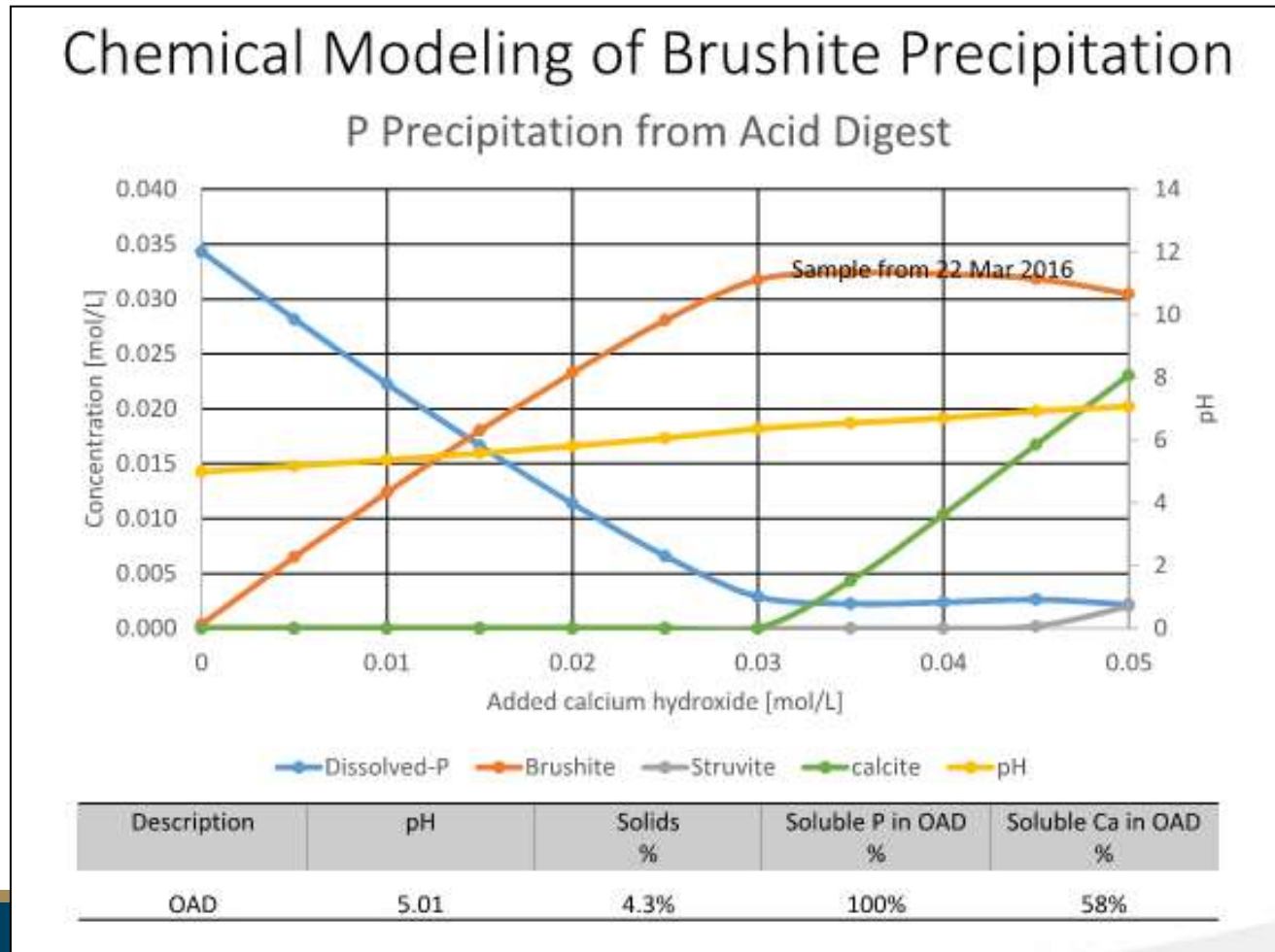

Alternatives for phosphorus removal & recovery

- **Ostara**
- **Multiform Harvest**
- **AirPrex**
- **NuReSys**
- **Nutrient Recovery & Upcycling (Brushite)**
 - **Now part of CNP**

Reference Installations

Technology	Number of Municipal Installations	Date of First Municipal Installation
AirPrex™	6 Operational (Europe) 3 In final design (US)	2009
NuReSys™	3 Operational (Europe)	2013 (first industrial 2006)
Ostara™	10 Operational (US) 6 In construction/design	2007
Multiform Harvest™	2 Operational (US) 1 In construction	2012
Brushite (CalPrex)	0	0

Ostara

P recovered from dewatering filtrate/centrate

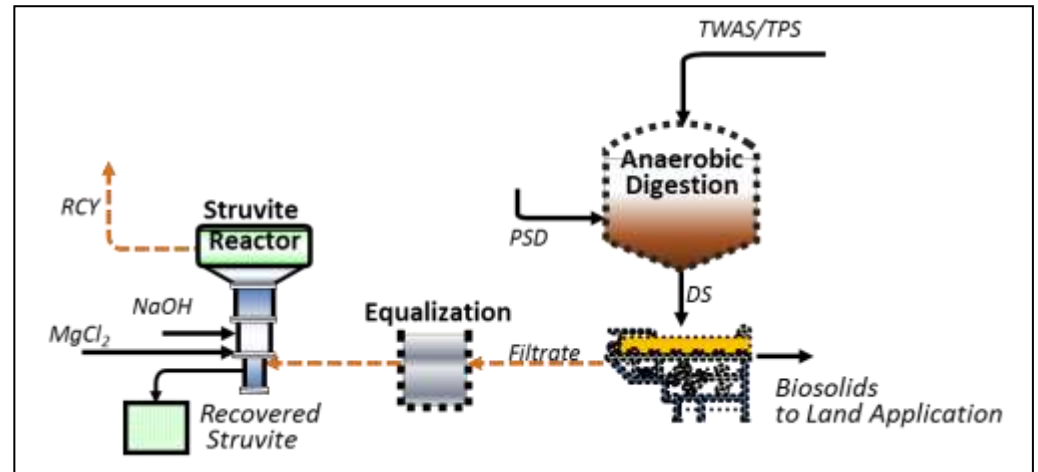

WASSTRIP

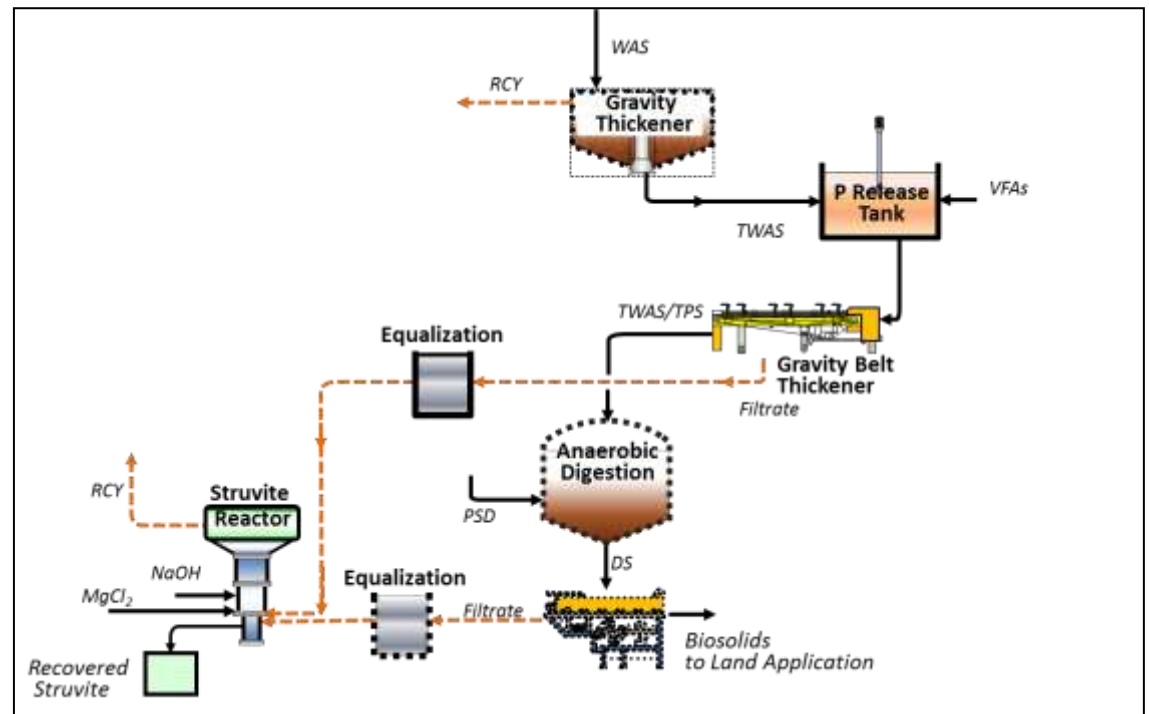

Ostara - WASSTRIP

- **Maximizes P recovery potential**
 - Less struvite precipitation in digesters
- **Reduces struvite scaling potential, *but does not eliminate it***
- **Reduces impacts to dewatering?**
- **More complex process than recovering from dewatering centrate/filtrate. Need for additional WAS thickening process.**

Multiform Harvest

- **Treat filtrate/centrate for recovery of struvite Pearls**
- **MultiWAS – Similar to WASSTRIP**
 - **Need to add ammonia to thickening filtrate reactor**
- **Reactor configured to make struvite crystals, not pearls**
 - **No recycle flow**



Multiform Harvest

P recovered from dewatering filtrate/centrate

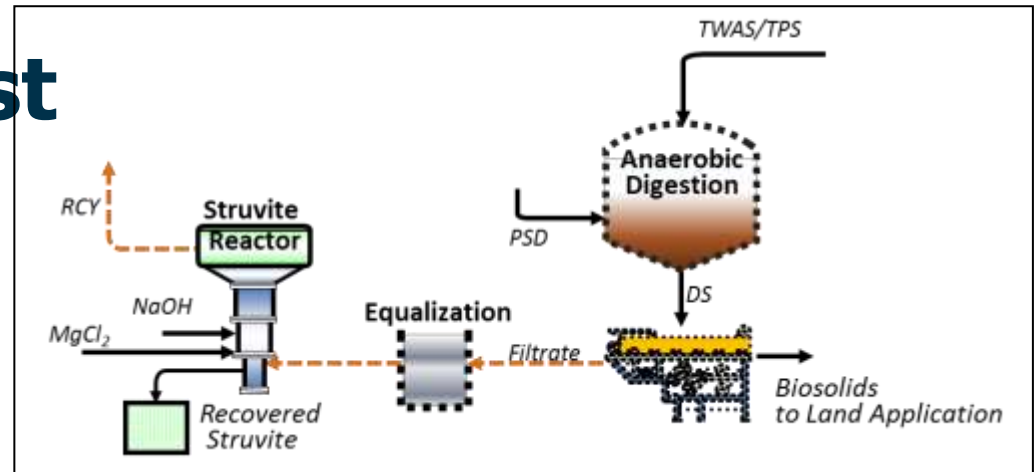

MultiWAS

MultiWAS maximizes P recovery

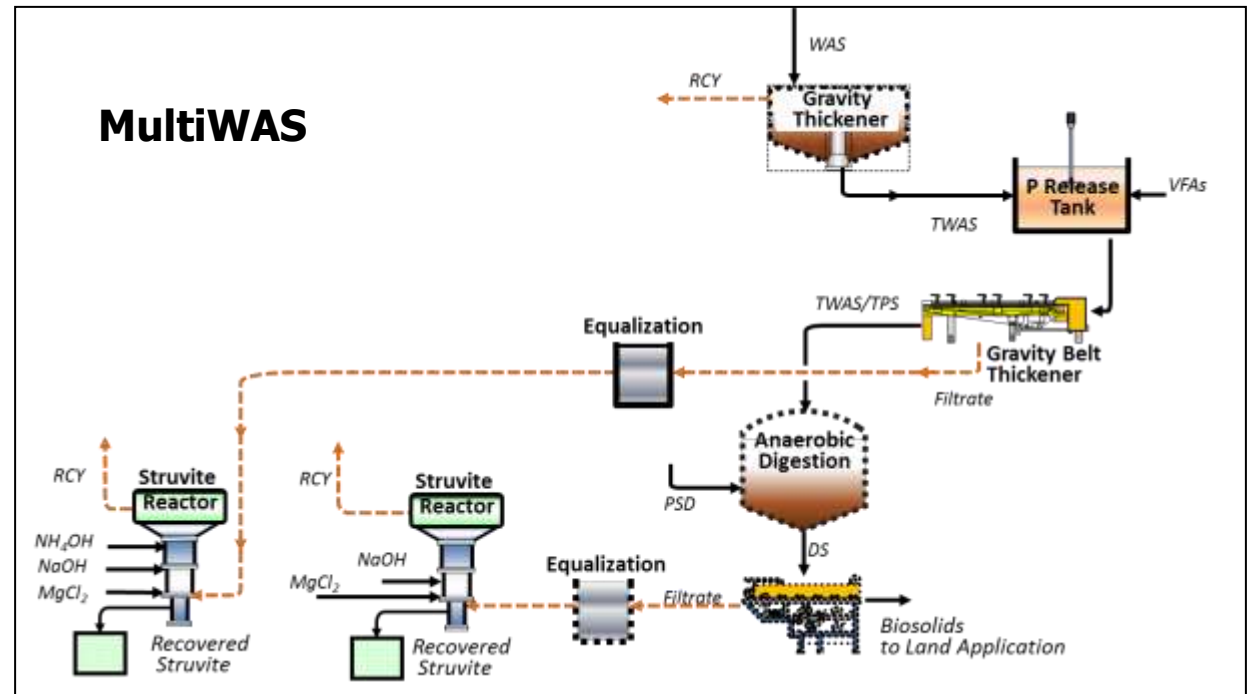

AirPrex

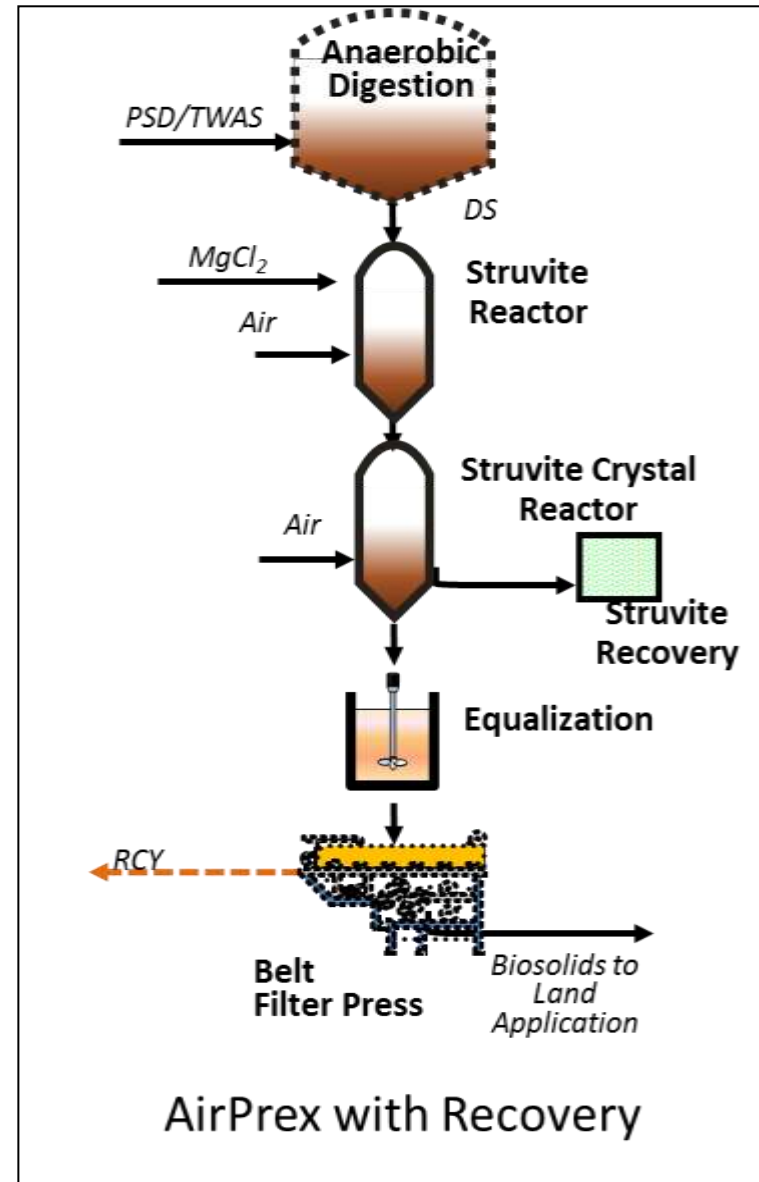
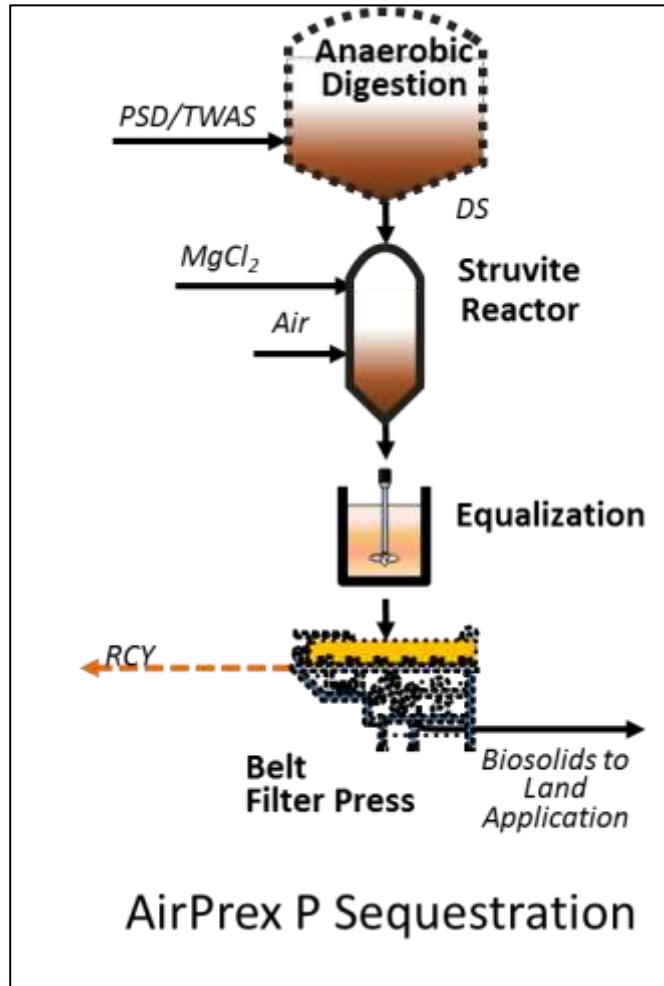

NuReSys

- May be configured on digestate, centrate/filtrate, or “hybrid”
- Air Stripper used to raise pH and precipitate Mg remaining after digestion
- Crystallizer used to precipitate additional ortho-P

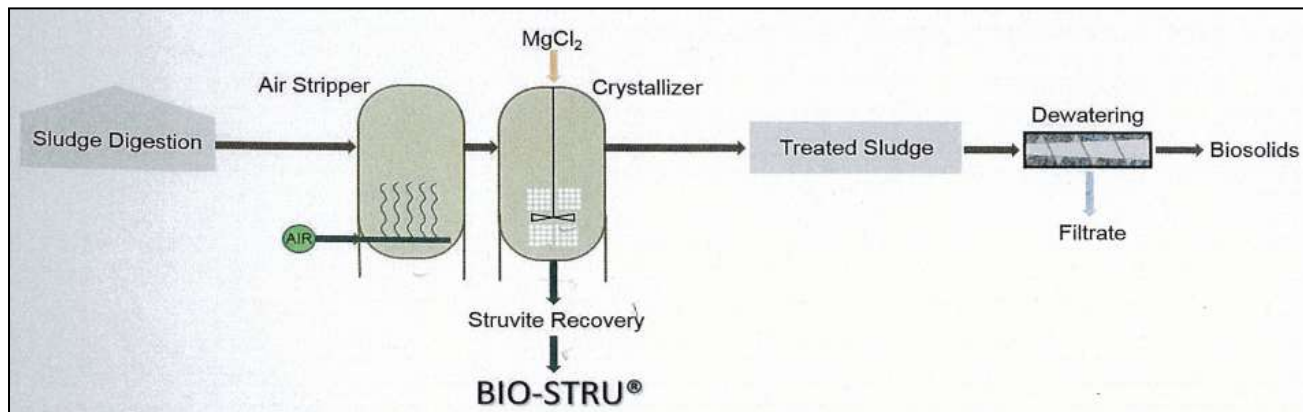

NuReSys

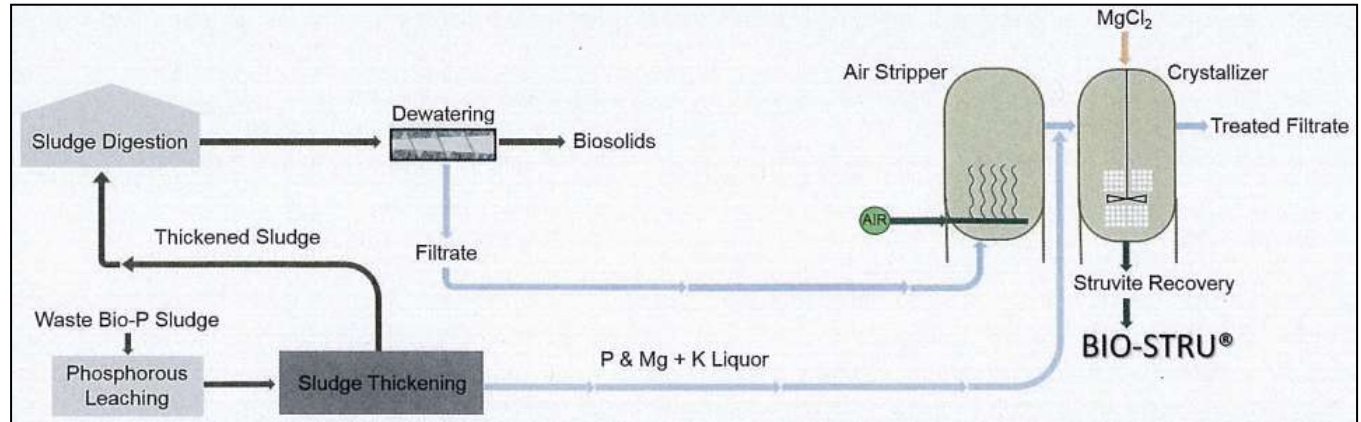

Centrate – WASSTRIP

**Hybrid
addresses
struvite
scaling
downstream
of digester**

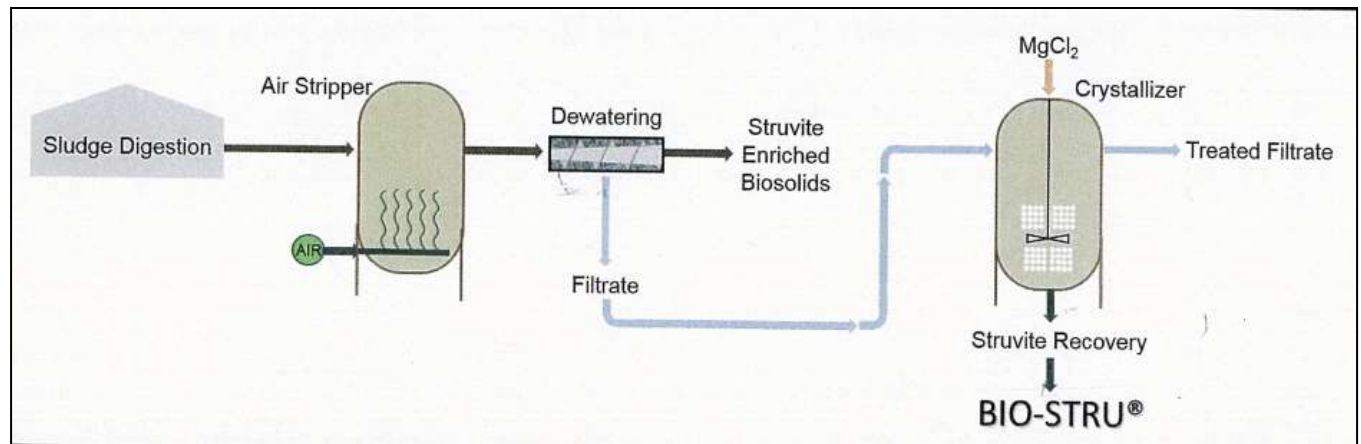

Hybrid

Brushite Recovery

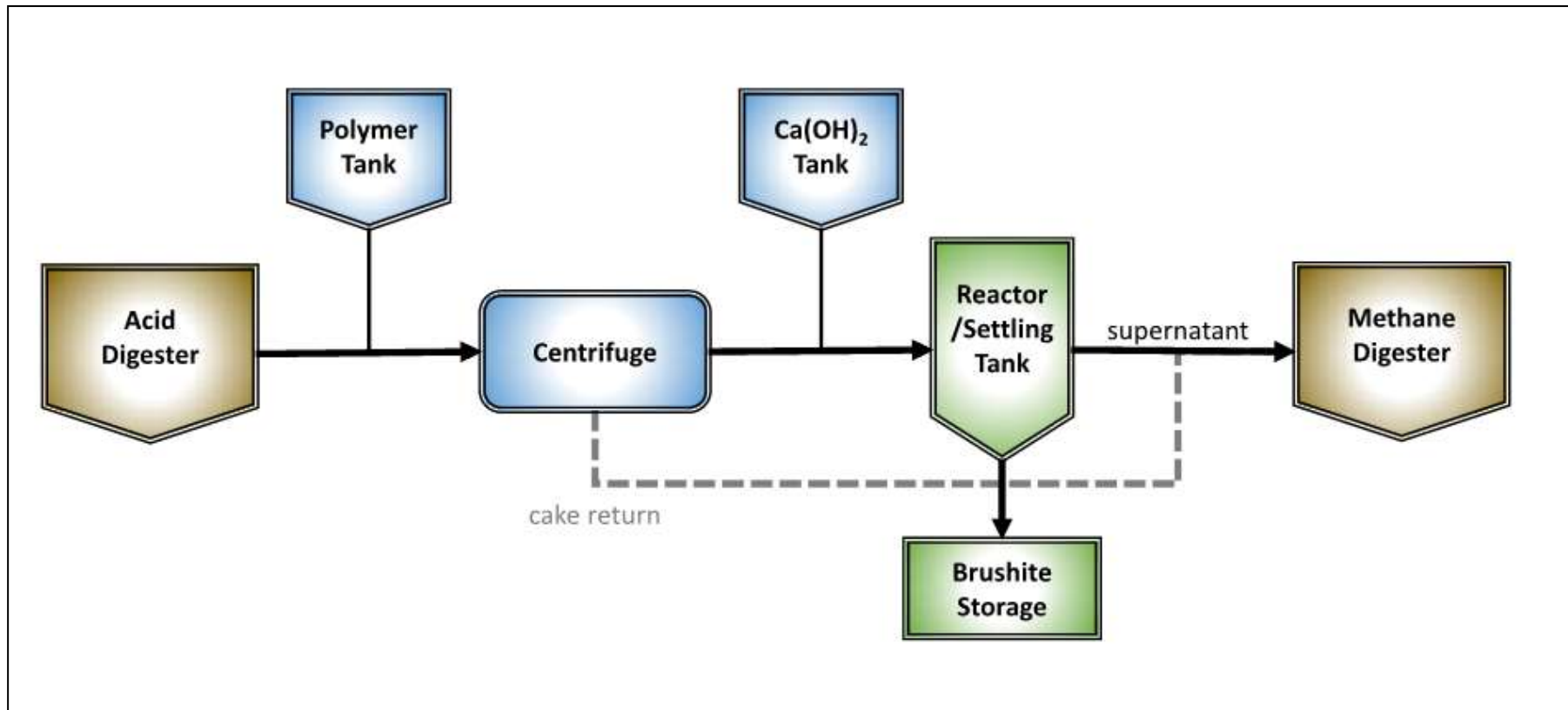

Advantages & Disadvantages

Technology	Advantages	Disadvantages
Ostara Pearl™	<ul style="list-style-type: none"> • Proven technology • High Ortho-P Recovery (90% of reactive P) 	<ul style="list-style-type: none"> • WASSTRIP process increases complexity
MHI Multifarm Harvest™	<ul style="list-style-type: none"> • Proven technology • High Ortho-P Recovery (90% of reactive P) • Smaller reactor than Ostara 	<ul style="list-style-type: none"> • MultiWAS process increases complexity • Requires additional chemical (NH₄OH)
CNP AirPrex™	<ul style="list-style-type: none"> • Easy to operate 	<ul style="list-style-type: none"> • Lower P recovery potential (<50% of reactive P) • No US installations
NuReSys Process™	<ul style="list-style-type: none"> • Easy to operate 	<ul style="list-style-type: none"> • Lower P recovery potential (<50% of reactive P) • No US installations
Brushite Recovery	<ul style="list-style-type: none"> • Highest potential for P recovery, recovers reactive and organically bound P 	<ul style="list-style-type: none"> • Emerging technology, no full scale installations

Nutrient Recovery take home message(s)

- **Reducing P in biosolids will reduce the impact of P on land application and nutrient management.**
- **P removal/recovery has in-plant benefits**
 - Improved dewatering
 - Reduced scaling
- **Recovered P fertilizers have market value**
 - Recovers a limited but misplaced resource
- **Many options available**

Current Trends in Biosolids Management & Treatment

**Thank You For
Your Attention!**

35th Annual
Spring
Biosolids
Symposium

March 21, 2017
Stevens Point, WI

Jay Kemp, PE, BCEE
Black & Veatch

Bill Marten, PE, BCEE
Donohue & Associates